

Symphony

Die als Sandwich- Konstruktion wirkende, mit Keramik beschichtete Magnesium Membrane vereinigt in ihrer Bauweise zwei Attribute, die eine exzellente Akustik garantieren: enorme Steifigkeit und ausgezeichnete Dämpfungseigenschaften.

The extremely stiff dome made of magnesium gives an outstanding high-note response with the best fine tuning.

A special shaped volume shell designed for minimum cavity resonance and extra fine damping material reduces sound reflections to a minimum.

The voice coil with aluminium wire cares for a high efficiency. The aluminium voice coil former stands for a high power handling.

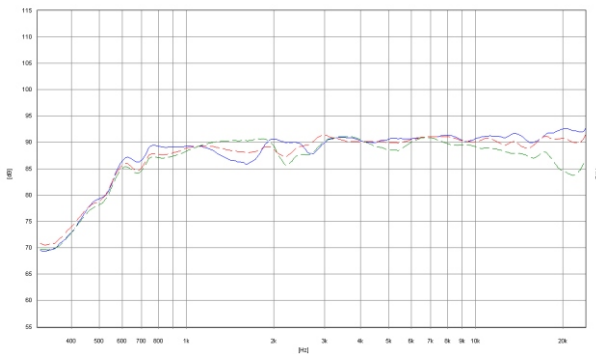
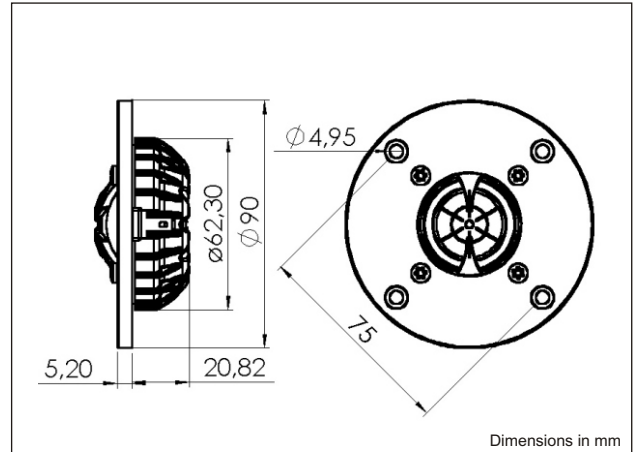

The frequency responses measured free field sound pressure in 0, 15 30 degrees angle using endless baffle. Input 2,83 VRMS, microphone distance 1 m

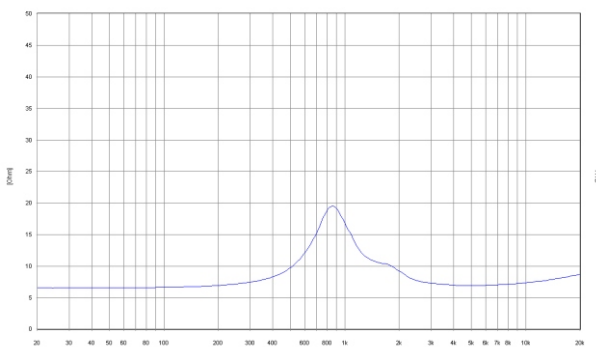

Impedance is measured free air without baffle.

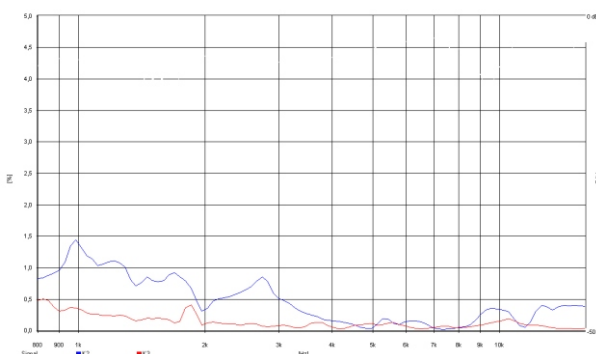

Distortion 1 Watt.

Nominal impedance	Z_n	8	
DC resistance	R_e	6.6	
Resonance frequency 1W	f_r	800	Hz
Suspension compliance	C_{MS}	-	mm/N
Mechanical Q	Q_{MS}	-	
Electrical Q	Q_{ES}	-	
Total Q	Q_{TS}	-	
Mechanical resistance	R_{MS}	-	kg/s
Total moving mass (including air mass)	M_{MD}	0.20	g
Effective piston area	S_D	6.8	cm ²
Voice coil diameter		25	mm
Voice coil former		Aluminium	
Voice coil length		1.3	mm
Voice coil layers		2	
Voice coil inductance	L_e	0.02	mH
Flux density	B	1.8	Tesla
Force factor	$B_L \times l$	3.7	Tm
Height of the gap		2.5	mm
Diameter of magnet		55	mm
Height of magnet		3	mm
Weight of speaker		0.27	kg
Characteristic SPL 1 Watt / 1 m		91	dB SPL
Rated power		100*	W
Equivalent air vol. of suspension	V_{AS}	-	dm ³

* with crossover

ETON reserves the right to change technical data

07/20