

TW022WA03 and -04 22 mm neodymium textile tweeters, 4 ohm

TW022WA03 and TW022WA04 are compact 22 mm neodymium tweeters for applications where small size is important, while requiring the highest level of performance

The best of two worlds?

The design with 22 mm voice coil and wide surround caters for both applications that would normally require traditional 3/4" tweeters and those, where 1" tweeters would usually be used. Featured with a rear chamber these compact tweeters offer very low resonance frequency.

Innovative

In order to keep distortion and resonance frequency low the TW022WA03/04 are designed around an external neodymium ring magnet in order to allow for a larger internal volume than that of traditional neodymium tweeter.

The dome shape and material choice allow for almost full output level to beyond 40 kHz.

The only difference between the two models is that TW022WA04 is shipped with an optimized face plate attached while TW022WA03 comes without face plate, for direct mounting in the enclosure/baffle.



TW022WA04

[Frequency resp.](#)
[Specifications](#)
[Dimensions](#)
[Ordering info](#)

MORE INFO

 PDF data sheet (XXMB)

[All Wavecor drive units](#)

[Technical pages](#)

FEATURES

- 22 mm design for optimal compromise between on- and off-axis frequency response, resonance frequency, and power handling
- Rear chamber for low resonance frequency and reduced distortion
- External ring neodymium magnet for lower resonance frequency and distortion
- Precision-coated textile diaphragm for improved consistency and high-frequency extension
- Optimized dome shape for ultra high frequency cutoff
- Vented voice coil former for reduced distortion and compression
- Copper-clad aluminium voice coil wire offering lower moving mass for improved efficiency and transient response
- Build-in cavities under dome/edge to equalize pressure for lower distortion and lower resonance frequency
- Flexible lead wires for higher power handling and larger excursion
- Gold plated terminals to prevent oxidation and ensure long-term reliable connection
- Delivered with EVA gasket attached for hassle-free mounting and secure cabinet sealing (TW022WA04 only)

SPL FREQUENCY RESPONSE

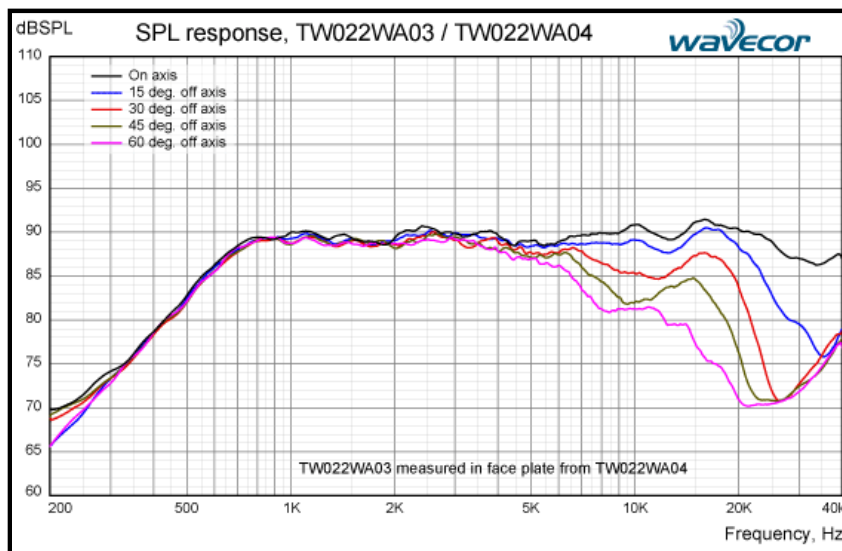

Measuring conditions, SPL
 Driver mounting: Flush in infinite baffle
 Microphone distance: 1.0 m
 Input level: 2.83 VRMS
 Smoothing: 1/6 oct.

IMPEDANCE RESPONSE

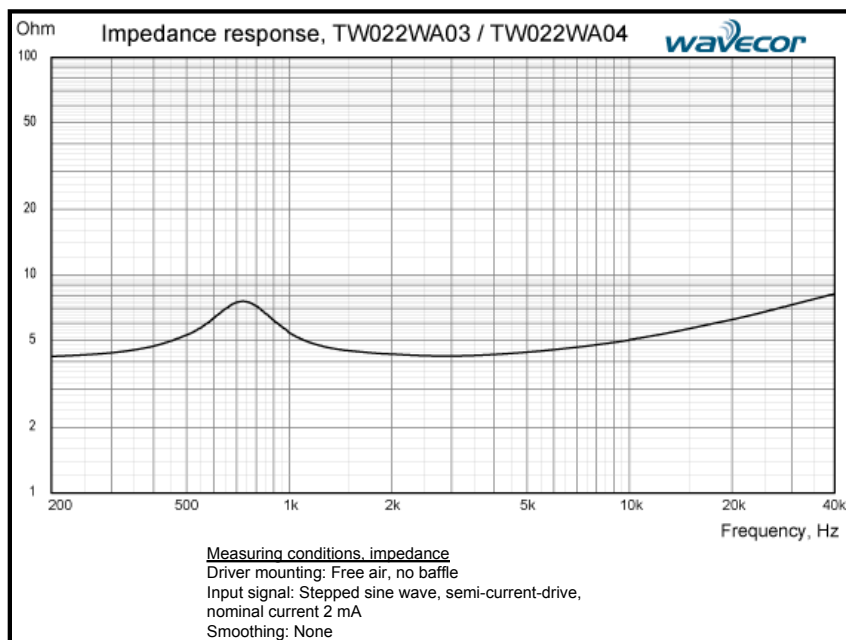

PRELIMINARY NOMINAL SPECIFICATIONS

Notes	Parameter	Value	Unit
	Nominal size	22	[mm]
	Nominal impedance	4	[ohm]
	Recommended frequency range	2 - 40	[kHz]
1, 5	Sensitivity, 2.83V/1m (average SPL in range 2 - 20 kHz)	89	[dB]
2	Power handling, short term, IEC 268-5, 3.0kHz@12dB/oct.		[W]
2	Power handling, long term, IEC 268-5, 3.0kHz@12dB/oct.		[W]
2	Power handling, continuous, IEC 268-5, 3.0kHz@12dB/oct.		[W]
	Effective radiating area, Sd	6.6	[sq.cm]
3, 5	Resonance frequency (free air, no baffle), Fs	750	[Hz]
	Moving mass, incl. air (free air, no baffle), Mms	0.21	[g]
3	Force factor, Bxl		[N/A]
3, 5	Suspension compliance, Cms		[mm/N]
3, 5	Equivalent air volume, Vas		[lit.]
3, 5	Mechanical resistance, Rms		[Ns/m]
3, 5	Mechanical Q, Qms		[-]
3, 5	Electrical Q, Qes		[-]
3, 5	Total Q, Qts		[-]
4	Voice coil resistance, RDC	3.8	[ohm]
6	Voice coil inductance, Le (measured at 10 kHz)		[µH]
	Voice coil inside diameter	22	[mm]
	Voice coil winding height	1.6	[mm]
	Air gap height	2.5	[mm]
	Magnet weight		[g]
	Total unit net weight excl. packaging		[kg]
3, 6	Krm		[mohm]
3, 6	Erm		[-]
3, 6	Kxm		[mH]
3, 6	Exm		[-]

Note 1 Measured in infinite baffle.

Note 2 Tested in free air (no cabinet).

Note 3 Measured using a semi-constant current source, nominal level 2 mA.

Note 4 Measured at 20 deg. C

Note 5 Measured at 25 deg. C

Note 6 It is generally a rough simplification to assume that loudspeaker transducer voice coils exhibit the characteristics of an inductor. Instead it is a far more accurate approach to use the more advanced model often referred to as the "Wright empirical model", also used in LEAP-4 as the TSL model (www.linearx.com), involving parameters K_{rm} , E_{rm} , K_{xm} , and E_{xm} . This more accurate transducer model is described in a technical paper (PDF) [here](#).

OUTLINE DRAWING AND NOMINAL DIMENSIONS, TW022WA03 (mm)

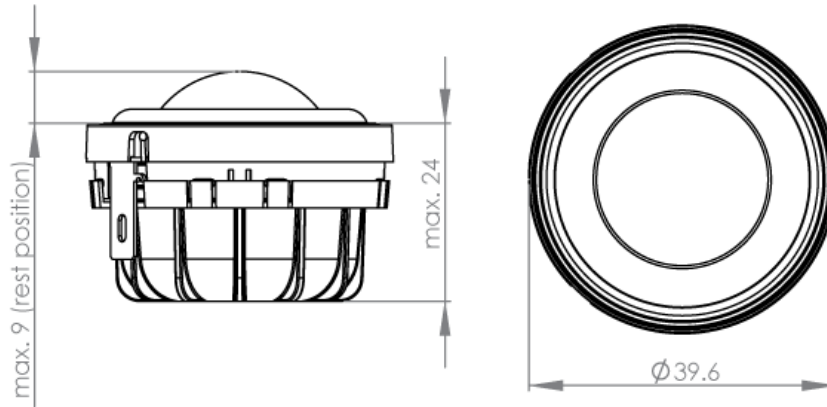

OUTLINE DRAWING AND NOMINAL DIMENSIONS, TW022WA04 (mm)

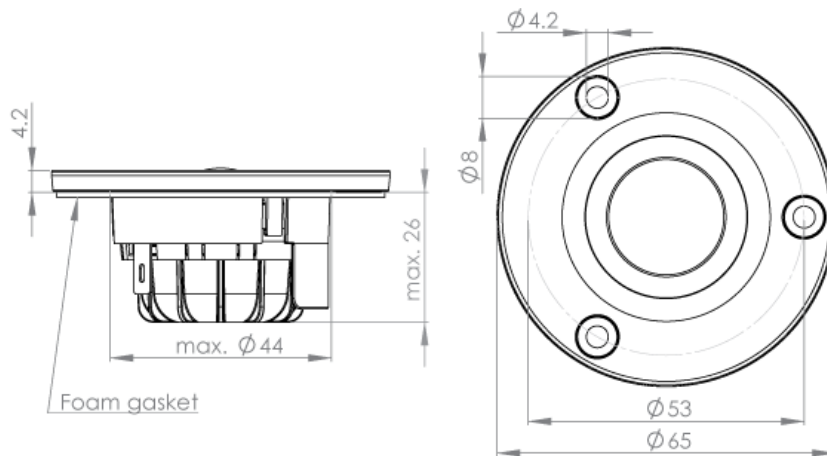

TERMINAL NOMINAL DIMENSIONS (mm)

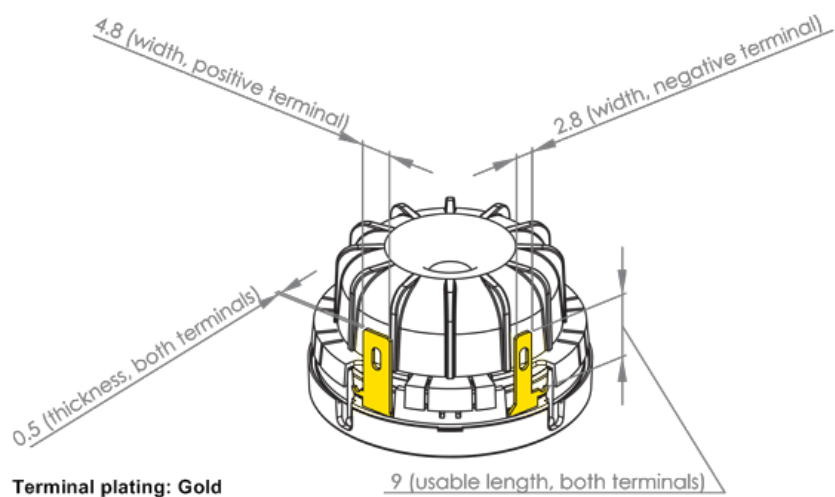

PACKAGING AND ORDERING INFORMATION

Part no. TW022WA03-01	Version without face plate, bulk packaging (OEM only)
Part no. TW022WA04-01	Version with face plate, individual packaging (one pair per box)
Part no. TW022WA04-02	Version with face plate, bulk packaging

Latest update: December 25, 2010

Specifications are subject to change without any further notice.
 Copyright © 2006-2010 by Wavecor Ltd., Guangzhou, China. All rights reserved.