

# ProTech-4 Series

## Owner's Manual and Installation Guide



Models	Part No.	Amperage	No. Of Banks	Volts
ProTech 1210	61210	10 Amps	2 Banks	12
ProTech 1215	61215	15 Amps	3 Banks	12
ProTech 1220	61220	20 Amps	3 Banks	12
ProTech 1230	61230	30 Amps	3 Banks	12
ProTech 1240	61240	40 Amps	3 Banks	12
ProTech 1250	61250	50 Amps	3 Banks	12
ProTech 2412	62412	12 Amps	3 Banks	24
ProTech 2425	62425	25 Amps	3 Banks	24
ProTech 3218	63218	18 Amps	3 Banks	32
ProTech 3616	63616	16 Amps	3 Banks	36

### IMPORTANT NOTICE

Please save and read all safety, operating and installation instructions before installing or applying AC power to the ProTech-4 series on-board battery charger.

For all product, installation or service questions please visit [www.promariner.com](http://www.promariner.com) or call ProMariner directly at 1.800.824.0524 between the hours of 8:30am to 5:00pm (Eastern Time)

### PLEASE RECORD YOUR:

model number: \_\_\_\_\_ serial number: \_\_\_\_\_ date of purchase: \_\_\_\_\_

## ▶ Table Of Contents

---

Safety Instructions...	pages 1-2
Overview...	pages 3
Installation Guidelines...	pages 3-6
Operation...	page 7
Battery Types & Charging Information...	page 8-9
Trouble Shooting...	page 9-10
Maintenance...	page 10-11
Frequently Asked Questions...	page 13-14
Accessories...	page 14
Customer Service & Warranty...	page 15

## ▶ Introduction

---

Thank you from all of us at Professional Mariner, LLC and congratulations on the recent purchase of your ProTech-4 Series On-Board Marine Battery Charger. The ProTech-4 is the latest in advanced cuddy, cruiser, sail, yacht and commercial on-board marine chargers.

The ProTech-4 charger incorporates industry leading fully automatic, true 4-step charging providing your batteries with a fast charge while conditioning and extending battery life. This advanced on-board charger has two user-selectable settings, Flooded / AGM or GEL cell.

### **Standard Features include:**

Industry leading package size: The ProTech-4 Series is the most compact charger of its kind in the industry. More amperage per cubic inch and the ability to mount in any position providing maximum installation flexibility.

Status Indicators: Fast Charge, Absorption, Float, Battery Type

### **4-Step Battery Charging:**

- 1) Fast Charge - Maximum current output until batteries reach 14.7 Volts.
- 2) Absorption Charge - Timed charge at 14.7 Volts - User Programmable
- 3) Float Charge - Reduce Voltage to 13.5 Volts
- 4) Recycle - If a continuous load draws down the battery; charger voltage returns to the high current Fast Charge mode.

World Wide Approvals and Certifications: Marine UL 1236/SA certified IMCI 8846 Ignition protected, and CE.

## ► General Safety Instructions

---

Before connecting your batteries or AC power, read all instructions and cautionary markings on the battery charger and batteries.

**CAUTION** - To reduce the risk of injury, charge only lead acid type rechargeable batteries (lead acid, sealed lead acid, GEL cell and AGM (Absorbed Glass Mat). Other types of batteries may burst, causing personal injury. The ProTech-4 series battery charger is factory set for lead acid (flooded) and AGM (Absorbed Glass Mat) batteries. **Check the position of the battery type selector switch before installation.**

Use of attachments not recommended or sold by Professional Mariner, LLC may result in a risk of fire, electrical shock or personal injury.

Do not operate the charger if it has received a sharp blow, direct hit of force, dropped or otherwise damaged in any way.

Do not disassemble the charger except for replacement of fuse. Call the factory directly when service or repair is required.

Incorrect assembly may result in risk of electrical shock or fire.

To reduce the risk of electrical shock, remove 120 Volt or 240 Volt AC power from the charger as well as 12, 24, 32, 36 Volt DC prior to any maintenance or cleaning.

### **WARNING**

**AVOID SERIOUS INJURY OR DEATH FROM FIRE, EXPLOSION OR ELECTRICAL SHOCK.**

- Make connection in an open atmosphere free of explosive fumes.
- Make connection in a secure manner that will avoid contact with water.

### **WARNING: RISK OF EXPLOSIVE GASES**

**WORKING IN THE VICINITY OF A LEAD ACID BATTERY IS DANGEROUS. BATTERIES GENERATE EXPLOSIVE GASES DURING NORMAL BATTERY OPERATION. FOR THIS REASON IT IS OF EXTREME IMPORTANCE THAT EACH TIME BEFORE USING YOUR CHARGER YOU FOLLOW THE SAFETY INSTRUCTIONS PROVIDED IN THIS MANUAL.**

To reduce risk of battery explosion, follow these instructions and those published by the battery manufacturer, and of any equipment you intend to use in the vicinity of a battery. Review all cautionary markings and labels.

## ► Personal Safety Precautions

---

Someone should be within the range of your voice or close enough to come to your aid when working near a lead acid battery.

Have plenty of soap and water nearby in case battery acid comes in contact with skin, clothes or eyes.

## ▶ Personal Safety Precautions Continued

---

Never smoke or allow a spark or flame in the vicinity of a battery or engine.

Wear complete eye protection and skin protection. Avoid touching eyes while working with a battery.

If battery acid contacts skin or clothing, wash immediately with soap and water. If acid enters the eye flood it with running cold water for at least 10 minutes and get medical attention immediately

Be extra cautious to reduce risk of dropping a metal tool onto a battery. It may spark or short-circuit the battery which could cause an explosion.

Remove all personal metal items such as rings, bracelets, necklaces, watches, and jewelry when working near a battery. A battery can produce a short circuit high enough to weld a ring or any metal, causing serious burns.

The ProTech-4 battery charger is not intended to supply low voltage electrical systems other than in a marine application. **Do not use the battery charger to charge dry cell batteries that are commonly used with home appliances.** These batteries may burst and cause injury to persons and property.

Never charge a frozen battery.

## ▶ Safety Precautions Prior to Charging Batteries

---

If necessary to remove a battery from a boat to charge, always remove grounded terminal from the battery first. Make sure all accessories in the boat are off, as to not cause an arc (sparking of the connection).

Be sure the area around the charger and batteries is well ventilated while the batteries are being charged. Gases can be forcefully blown away using a piece of cardboard or other nonmetallic material as a fan.

Clean battery terminals with full eye protection to prevent corrosive material from coming in contact with eyes.

Add distilled water (**not tap or bottled water that contains minerals**) in each cell until electrolyte reaches levels specified by the battery manufacturer. Do not overfill. For batteries without caps, carefully follow manufacturers' recharging instructions.

Study all manufacturers' specific precautions before charging, in addition to rates of charge.

## ► General Overview

---

The ProTech-4 battery charger will operate from 90 to 270 VAC, 45 to 440 Hz single phase. The charger is designed specifically for the marine environment, with an anodized aluminum case for effective heat dissipation and corrosion resistance. The charger should be permanently mounted in your boat and wired directly to your batteries. Three isolated positive outputs are incorporated to sense and charge three separate heavy-duty batteries or battery banks as needed.

The ProTech-4 battery charger is reverse polarity protected and is equipped with two cooling fans for optimum performance. The ProTech-4 battery charger's fans will not run at all times. The fan will turn on as needed for cooling.

## ► Installation Guidelines

---

The charger should be securely fastened with stainless steel screws or through-bolts with lock nuts. Vertical mounting on a bulkhead is preferred, but mounting in any position that allows air to circulate with six inches of clearance space on all sides is required. The ProTech-4 battery charger operates at ambient temperatures up to 50 degrees C/140 degrees F.

The Protech-4 has a fuse block on the negative side (30 amp and larger) to protect the charger from reverse polarity. 10, 15 and 20 amp chargers have a reverse polarity fuse located inside the unit.

The 30 amp and larger chargers in the ProTech-4 family are equipped with an AC input selector switch to change the Voltage from 120 Volt to 240 Volt. Smaller chargers with less than 30 amp output do this automatically. (Voltage switch shown below)

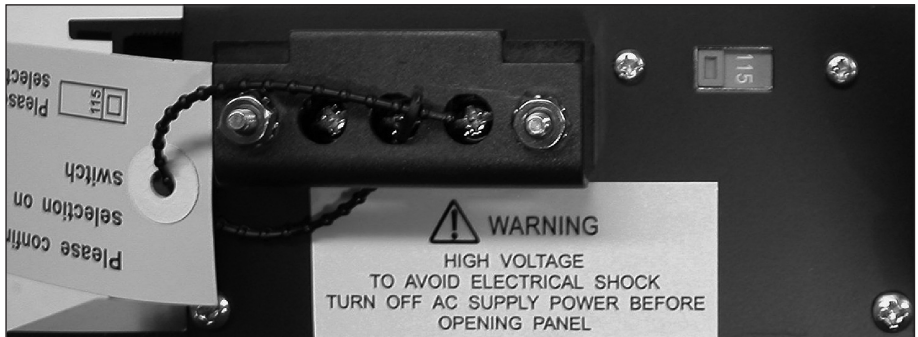

## Internal Switches

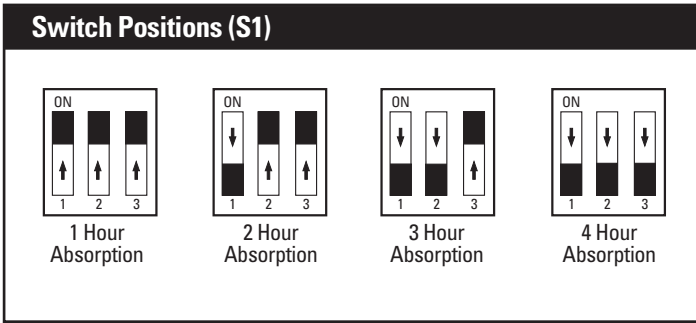

Shown (above) is a diagram for the switch positioning. Example: all switches in the up position as shown on the diagram equal 1 hour absorption time.

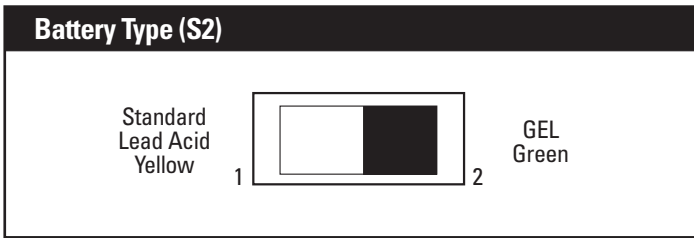

Shown (above) is the battery type indicator switch. The absorption LED will illuminate green when set to GEL cell. The absorption LED will show yellow in the Lead Acid and AGM (Absorbed Glass Mat) setting. Shown in GEL mode.

### Actual Switches



Shown (above) - The charger is set for four hour absorption flooded (Lead Acid)

## ▶ 12 Volt Wiring Diagrams

### Three Bank Wire Installation

A) Batteries negative wires are run separately to the boats DC bus bar (not provided). Then a single connection is made to the chargers negative stud.

B) 3 separate positive wires attach to the 3 positive posts on the charger.

### Two Bank Installation

When wiring for two batteries you will need to use the jumper wire provided. The jumper goes on the unloaded positive terminal and connects to an adjacent positive terminal (Note: do not leave a terminal post unloaded).

### One Bank Installation

(See above) Use the provided jumper wire and create another. We recommend crimped or soldered connections and 14 AWG wire. (Note: do not leave a terminal post unloaded).

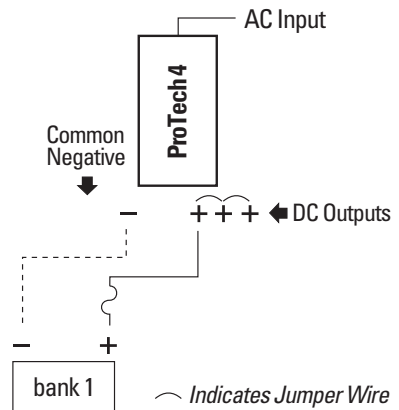
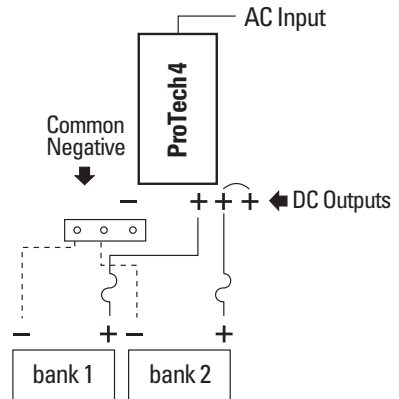
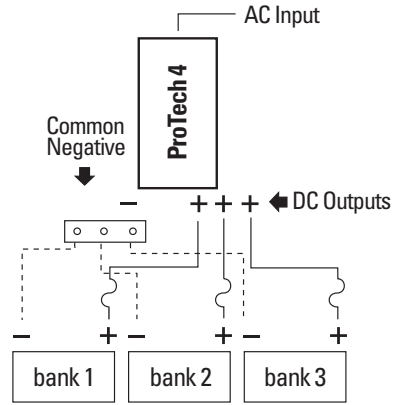

⌋ Indicates Jumper Wire

12 Volt 30 Amp	Length Out and Back				
Wire length	10'	15'	20'	25'	30'
AWG	10	8	6	6	4
<b>12 Volt 40 Amp</b>					
Wire length	10'	15'	20'	25'	30'
AWG	8	6	6	4	4
<b>12 Volt 50 Amp</b>					
Wire length	10'	15'	20'	25'	30'
AWG	6	6	4	4	2
<b>24 Volt 25 Amp</b>					
Wire length	10'	15'	20'	25'	30'
AWG	12	12	10	10	8
<b>36 Volt 15 Amp</b>					
Wire length	10'	15'	20'	25'	30'
AWG	14	12	12	10	10
<b>32 Volt 16 Amp</b>					
Wire length	10'	15'	20'	25'	30'
AWG	14	12	12	10	10

## Installation



*Note: The charger can be mounted horizontally (shown) or can be mounted vertically. Make sure to allow for at least 6 inches clear space around the charger for ventilation*

### Recommended AC Breaker

120 VAC Single Phase		240 VAC single
12 volt 10 amp	10 amp	5 amp
12 volt 20 amp	10 amp	5 amp
12 volt 50 amp	20 amp	10 amp
12 volt 40 amp	20 amp	10 amp
12 volt 30 amp	15 amp	8 amp
24 volt 20 amp	10 amp	5 amp
24 volt 25 amp	15 amp	8 amp
32 volt 8 amp	8 amp	5 amp
32 volt 16 amp	15 amp	5 amp
36 volt 8 amp	8 amp	5 amp
36 volt 15 amp	10 amp	5 amp

1) Make sure to mount the charger in a dry ventilated location with easy access. Remember to leave plenty of room for battery cables and AC (120 Volt or 240 Volt) wires.

2) It may be helpful to create a template for mounting or to use the ProTech-4 as a template for drilling four 1/8" pilot holes. Pilot holes help to prevent the material from cracking or splinting while inserting a screw.

3) Battery cable wires should comply with ABYC A-20 standards, more importantly is that **each ungrounded DC conductor shall be provided with an over current protection fuse within 7 inches of connection to the DC electrical system or to the battery.** The fuse rating should be 10 to 20 amps higher than the rated full output of the charger. Normally protection would be necessary at the charger end of this wire but because the ProTech-4 series charger is self limiting (can not exceed its rated current output) no fuse is necessary at the charger output. The provided fuse in the negative lead protects the charger against an inadvertent reverse polarity connection.

4) We recommend strain relief on the cables within 6" of the charger for both AC and DC conductors. Connect the DC cables to the charger first then to the batteries. Connect positive battery end first, then connect the negative cables at the batteries.

5) Be cautious when connecting battery cables to the ProTech-4 charger and check to make sure AC power is off. Be careful when placing battery cables near one another to avoid possible shorting or arcing (sparking) that can occur when positive and negative wires touch.)

6) After all cables are in place check connections one last time and make sure all connections are tight and that the charger is located in a dry place. **Water damage will not be covered under the warranty.**

7) Apply power and check to see that the LED lights are lit. If no LED's are observed check shore power AC (120 or 240 Volt connections). If LEDs are still not lit review the testing procedure on (Page 9).

**AC CONNECTIONS:** A terminal strip is provided on the charger for AC input. Connect Black (hot/line) (Europe-Brown) to connection marked L. Connect White (neutral) (Europe-Blue) to connection marked N. Connect Green (Earth/Ground) (Europe-Green/Yellow) to connection marked Earth. Install a circuit breaker dedicated to the charger at the boat's electrical panel to protect the AC wire to the charger.

**Minimum AC wire size (105° C wire) - 16 gauge however, 14 or 12 is recommended. (See ABYC E-11 for exact wire sizes for length of run, ampacity, temperature, location and number of wires in bundles.)**



## ► Operation

When the charger is activated, the YELLOW Fast Mode LED and ORANGE Boost LED will be lit. If lead acid/GEL cell switch is in GEL position, top LED will be GREEN instead of YELLOW. (LEDs shown below)

*Note: It is not recommended that you charge different battery types and sizes. The charger is design to charge similar battery types and sizes; any other combination can cause the charger to over or undercharge and is not recommended.*

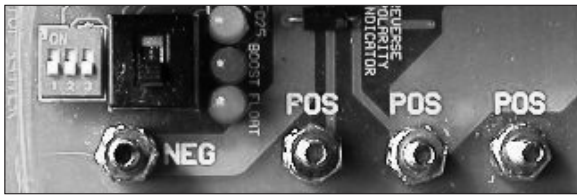

Battery Type	12 Volt Absorption & Float Voltages	24 Volt System	32 Volt System	36 Volt System
Flooded (Lead Acid)	14.7 Absorption, 13.5 Float	29.4 Absorption, 27.0 Float	39.2 Absorption, 36.0 Float	44.1 Absorption, 40.5 Float
AGM (Absorbed Glass Mat)	14.7 Absorption, 13.5 Float	29.4 Absorption, 27.0 Float	39.5 Absorption, 36.0 Float	44.1 Absorption, 40.5 Float
GEL Cell (Gelled Electrolyte Lead-Acid)	14.1 Absorption, 13.5 Float	28.2 Absorption, 26.6 Float	37.6 Absorption, 36.0 Float	42.3 Absorption, 40.5 Float

After the Fast Charge cycle, Absorption time is determined by the position of the three timer switches. (Shown on page 4)

The ProTech-4 battery charger will operate for the selected absorption time whenever AC power is applied.

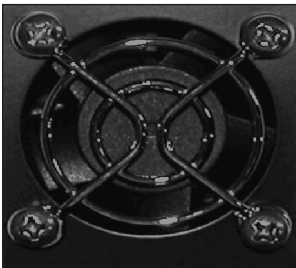

Full-rated current is available in Float Mode. Voltage will normally be above charged battery Voltage at full output.

When the Voltage falls below 11.5 Volts, or if the AC power is applied, the Fast Charge cycle will start.

Battery charger fan(s) will turn on only as needed to control temperature, the fans will not run continuously unless needed.

*Note: for your safety the charger is equipped with an internal temperature sensor that will turn off the charger in extreme heat.*

## ▶ Battery Types

There are three primary types of batteries in the marketplace today; Flooded (Lead Acid), AGM (Absorbed Glass Mat) and GEL Cell (Gelled Electrolyte Lead-Acid). Traditionally, the most common type of batteries used are Flooded (Lead Acid batteries).

AGM batteries are often mistaken as GEL batteries

Almost all GEL Cell batteries will state that they are GEL Cell on the battery case or labels.

Battery Type	Charging Profile	Battery Information
Flooded (Lead Acid)	14.7 Absorption, 13.5 Float	Water filled (with or without Removable caps)
AGM (Absorbed Glass Mat)	14.7 Absorption, 13.5 Float	Sealed
GEL Cell	14.1 Absorption, 13.5 Float	Sealed

**NOTE:** AGM (Absorbed Glass Mat) batteries are not GEL (Gelled Electrolyte Lead-Acid) batteries. AGM batteries are charged at the same charging profile as Flooded (Lead Acid).

\*\*\*If you are still unsure as to what kind of battery you have, we recommend that you contact the manufacturer of the battery.

**CAUTION:** When installing a ProTech-4 battery charger in a vessel with a generator be aware the charger is designed to charge batteries of similar size. Generator batteries are usually significantly smaller potentially causing the charger to overcharge the generator battery. We recommend that the generator battery receive a battery maintainer available from ProMariner.

**See Accessories Page for information on maintainers or at [www.promariner.com](http://www.promariner.com)**

## ▶ Battery Types Continued

Dry Mount Chargers					Cruising and Sailing					
Model Number	Model Name	Charger Output	Total Charger Output	No. of Batteries	Combined Total Number of Battery Amp Hours*					
					0-95	95-195	195-295	295-395	395-595	595-895
61210	ProTech-4 1210	12 Volts	10 Amps	2 Bank	5 Hrs	10 Hrs				
61215	ProTech-4 1215	12 Volts	15 Amps	3 Bank	3 Hrs	6 Hrs	10 Hrs			
61220	ProTech-4 1220	12 Volts	20 Amps	3 Bank		5 Hrs	7 Hrs	10 Hrs		
61230	ProTech-4 1230	12 Volts	30 Amps	3 Bank		3 Hrs	5 Hrs	7 Hrs	8 Hrs	
61240	ProTech-4 1240	12 Volts	40 Amps	3 Bank				5 Hrs	8 Hrs	11 Hrs
61250	ProTech-4 1250	12 Volts	50 Amps	3 Bank				4 Hrs	6 Hrs	9 Hrs
62412	ProTech-4 2412	24 Volts	12 Amps	3 Bank		8 Hrs	10 Hrs			
62425	ProTech-4 2425	24 Volts	25 Amps	3 Bank		4 Hrs	6 Hrs	8 Hrs	10 Hrs	
63218	ProTech-4 3218	32 Volts	18 Amps	3 Bank			8 Hrs	10 Hrs		
63616	ProTech-4 3616	36 Volts	16 Amps	3 Bank			9 Hrs	12 Hrs		

All ProMariner chargers can be wired in parallel. For example if you need 100 amps to recharge your batteries, you can run two Protech 1250's (our 50 Amp battery charger) in parallel to get 100 Amps (doubling the amperage)

## ▶ Troubleshooting

This testing procedure has been provided should you feel your charger is not functioning correctly.

**Note: When working with tools near electricity serious electrical shock can occur resulting in injury.**

- 1) Turn off all power to the charger and disconnect all the DC cables at the batteries.
- 2) Making sure the cables are not touching each other, apply AC (120 Volt or 240 Volt). The charger should be in either the Fast Charge Mode or the Absorption Charge Mode. Check the Voltage between each positive and negative lead Voltage should be 14.7 Volts (for lead-acid batteries) or 14.1 (for GEL cell batteries).

## ▶ Troubleshooting Continued

3) If the Voltage is correct keep the charger powered up but disconnected from the batteries number of hours as set by the (S1) dipswitches (shown on Page 4) The green LED should become illuminated. Recheck the Voltage; it should be 13.5 Volts Lead Acid and 13.5 Volts for GEL from each positive lead to the negative lead.

4) If you see all of the above, your charger is most likely working correctly.

5) If you do not see the initial 14+ Volts, the charger either has a blown fuse, or circuit board failure. Turn off AC power; remove the small cover and the large cover with the fan. The fan and the AC (120 Volt or 240 Volt) terminal block are attached to the main circuit board. There is a glass cylinder fuse (AC fuse) if it is blown replace it (the fuse says 250 Volts- however if your boat doesn't leave the United States and is a 30 Amp service. It can replace with a 120 Volt same amperage fuse. If it blows a second time then a circuit board failure has occurred.

**Professional Mariner Customer Service 1-800-824-0524 or email [info@pmariner.com](mailto:info@pmariner.com)**

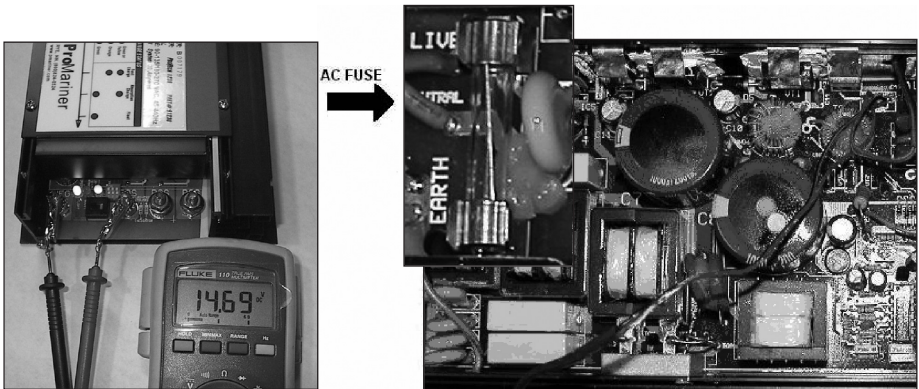

## ▶ Periodic Maintenance

<b>Process:</b>	Per battery manufactures instructions monitor and maintain proper levels of distilled water (not tap or bottled water that contains minerals) in each battery.
<b>When:</b>	Monthly

## ► Periodic Maintenance Continued

<b>Process:</b>	Per battery manufactures instructions monitor and maintain proper levels of distilled water (not tap or bottled water that contains minerals) in each battery.
<b>When:</b>	Monthly
<b>Process:</b>	Visually inspect all wiring for cuts and abrasions. Contact ProMariner if charger needs to be serviced.
<b>When:</b>	Monthly
<b>Process:</b>	Check charger for water damage.
<b>When:</b>	Monthly

## ► Technical Information

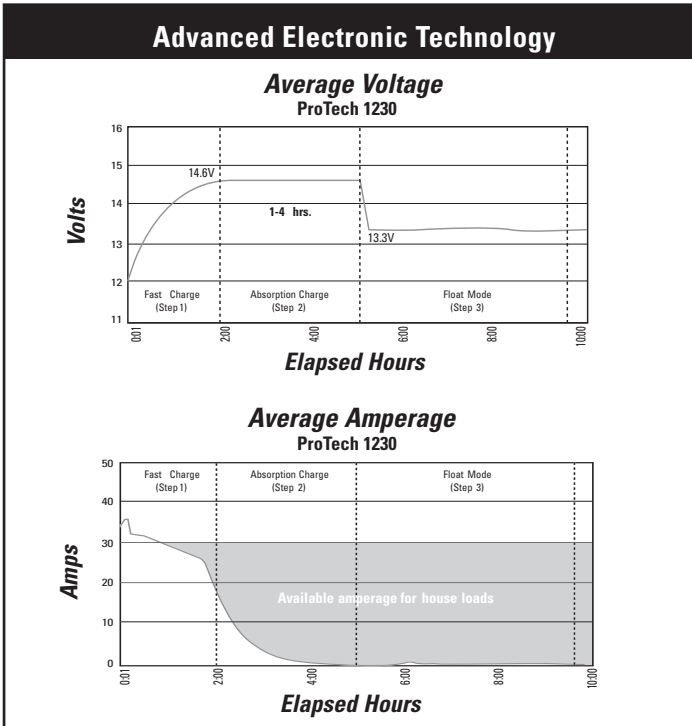

## ▶ Technical Information Continued

### No LEDs

The charger appears to have a series of LED lights on the outside in plan view. This is not the case; the charger actually has a viewing hole on the battery connection side. The LED's will only light up when the unit has AC (120v or 240v) power.

### GEL Cell charging mode

First, make sure that the charger is off and has no power. By removing the small cover where the battery cables are located observe the black switch with two positions, position 1 is for Lead Acid batteries and AGM (Absorbed Glass Mat). Position 2 is for GEL cell batteries. The Protech-4 is also equipped with an indicator light that illuminates yellow for Lead Acid /AGM and green for the GEL cell setting.

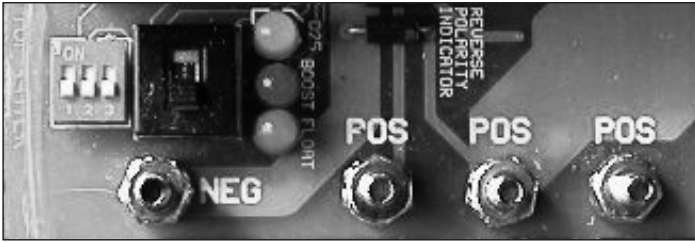

### External Fuse Box (for 30 Amp Units and Larger)

The fuse box outside the charger with a yellow cable attached is for negative DC (12 Volt) reverse polarity protection, design to protect the charger from reverse polarity (reversing negative and positive wires) this feature protects the charger from damage.

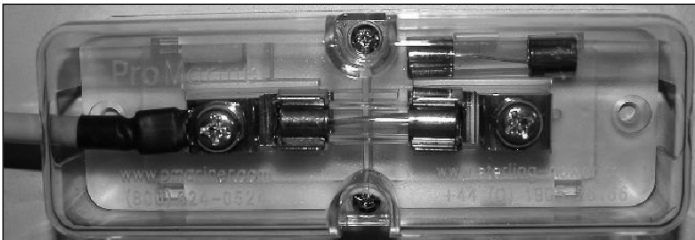

*Note: When changing the configuration of your charger, make sure AC power is disconnected.*

## ► Frequently Asked Questions

---

**Q: Do I have GEL Cell batteries?**

A: The best way to determine is to look at the battery housing and see if it is identified as a GEL battery. If you don't know contact the manufacturer of the battery.

**Q: I am not having any LEDs illuminate?**

A: (Note that there are no LEDs on the front of the charger, they are located under the access panel on the 12 Volt DC side). 1) Check to make sure there is AC power connected. 2) Disconnect AC power, check the AC fuse inside the charger located underneath the cover; being careful when removing the large access plate (fan wire attached). On the AC (120 Volt or 240 Volt) side of the charger you will find the small cylinder style fuse. Replace the fuse with the same amperage fuse and then apply AC power. If problem still exists contact Professional Mariner 1-800-824-0524.

**Q: Will water hurt my charger?**

A: Yes, these are dry mount chargers and are intended to be mounted in a dry location. Professional Mariner does not warranty water damaged chargers.

**Q: How do I change my charger to GEL cell mode?**

A: Please double check that you have GEL cell batteries. There is a misconception that AGM is GEL. This is not the case. AGM (Absorbed Glass Mat) batteries charge at Lead Acid levels. Remove the access cover on the (12 Volt) DC Voltage end and switch the black toggle switch to position 2 the green LED will illuminate to indicating that the charger is in GEL cell mode.

**Q: Is it ok to mount my charger on carpeting?**

A: Yes, in most cases this is not an issue, however we recommend mounting the charger to a board first. Proper ventilation must be maintained.

**Q: Do the chargers really need 6" clearance for ventilation?**

A: We recommend this for cooling, more clearance is better.

**Q: I think my charger is too hot. What should I do?**

A: The charger will get to the point where it can be touched, but you would not want to carry it across a room. This is normal. Note: the charger is thermally protected.

**Q: I have 3 output posts and 2 batteries?**

A: Using the provided jumper wire connect the unused post to a post which is connected to a battery. This will allow the charger to perform correctly and distribute power more effectively. (See wire diagrams on Page 5).

**Q: I have 3 positive posts and 1 battery?**

A: (See above) Make another jumper wire using 14 AWG wire and solder the ring terminals on to the wire.

## ► Frequently Asked Questions Continued

---

**Q: What are the voltage requirements and how can I change the voltage from 120v to 240v?**

A: The ProTech-4 Series battery charger is set to work at 120 Volts but can be switched to accept 240 Volts.

*Note: that ProTech-4 battery chargers less than 30 amps automatically adjust for correct voltage. The switch is located on the AC side of the unit and is a slide switch that indicates the voltage level either 120v or 240v. The charger will operate from 90 to 270 Volt AC, 45 to 440 Hz single phase.*

**Q: What is the recommended absorption time?**

A: The simple rule of thumb is: the larger the battery bank, the longer the absorption time. We suggest the following

- Single Group 24 or Group 27... 2 Hours
- Two Groups 24, 27 or Single Group 31... 3 Hours
- Single 4D or 8D... 4 Hours
- Multiple 4 or 8Ds of Multiple 6 V... 4 Hours

## ► Optional Accessories

---

**Optional Battery Bank Status Monitor**

See your local dealer or retailer for the ProMariner Remote Battery Bank Status Monitor. The Remote Monitor is easy to install and connects directly to your boats batteries. Once installed simply hold down the "Push-To-Test" button and observe the charge level indicator for each battery. (Up to 3 batteries can be monitored). Note: AC power and the boats engine must be off when using the Remote Battery Bank Status Monitor.

model	part no.	cable size	volts	banks
Handheld DC System Tester	87710	n/a	n/a	n/a
Digital Multi-Meter	60016	3'	12	3
ProSport 1.5 Portable	10115	4'	12	1
ProSport 1.5 On-Board	10116	4'	12	1
Clamp-It Multimeter	87015	n/a	n/a	n/a
ProSafe 1 Single Line Galvanic Isolation System	22086	n/a	120	n/a
ProSafe Isolation Transformers 3.6-12KVA	n/a	n/a	120/240	n/a
Adjustable Corrosion Monitoring System	22020	n/a	n/a	n/a
Corrosion Monitoring System	22030	n/a	n/a	n/a
Corrosion Workbook	20001	n/a	n/a	n/a

To Place an Order Please Contact Your Local Dealer or ProMariner at:  
 Tel: 603-433-4440 / Fax: 603-433-4442 / [www.promariner.com](http://www.promariner.com)



## ▶ Customer Service & Warranty

---

We are committed to customer satisfaction and value your business. If at any time during the warranty period you experience a problem with your ProTech-4 Series On-Board Marine Battery Charger call us at 1-800-824-0524 or email for technical support.

WARRANTY CARD CAN BE REGISTERED AT [WWW.PROMARINER.COM](http://WWW.PROMARINER.COM)

### PROTECH-4 SERIES ON-BOARD MARINE CHARGER ONE YEAR LIMITED WARRANTY LIFETIME REPAIR POLICY

Each ProMariner ProTech-4 Series Model is guaranteed against defects in material and workmanship to the original purchaser in normal use for one full year after purchase.

Each serial numbered product has an additional repair adjustment provision after the year limited warranty that limits the maximum charge for a factory repair to the original purchaser to 1/60 of the list price times the months after purchase (minimum 12) or up to 50% of the list price, after 30 months service, plus shipping.

- Warranty and repair adjustment calculated from manufacture date if not registered within two weeks of sale.
- Warranty void if unauthorized repairs attempted.
- Customer is responsible for shipping damages to ProMariner.
- Cosmetic repairs are done at the owner's request and expense.

Purchase or other acceptance of the product shall be on the condition and agreement that Professional Mariner, LLC SHALL NOT BE LIABLE FOR INCIDENTAL OR CONSEQUENTIAL DAMAGES OF ANY KIND. (Some states do not allow the exclusion or limitation of incidental or consequential damages, so the above limitations may not apply to you.) This warranty is made in lieu of all other obligations or liabilities on the part of Professional Mariner. Professional Mariner neither assumes nor authorizes any person for any obligation or liability in connection with the sale of this product.

To make a claim under warranty, go to [www.promariner.com](http://www.promariner.com) and click on the support tab and follow the instructions making sure to identify the product and the problem. Professional Mariner will make its best effort to repair or replace the product, if found defective within the terms of the warranty, within (30) days after return of the product to the company. Professional Mariner will ship the repaired or replaced product back to the purchaser.

This warranty gives you specific legal rights, and you may also have other rights, which vary from state to state. This warranty is in lieu of all others expressed or implied.

Factory Service Center & Technical Offices  
Professional Mariner, LLC  
200 International Drive, Suite 195  
Portsmouth, NH 03801  
Tel: 1-800-824-0524

ProTech-4 Series On-Board Marine Charger  
Tel: (603) 433-4440 / Fax: (603) 433-4442

[www.promariner.com](http://www.promariner.com)

▶ **Visit ProMariner Online at [www.promariner.com](http://www.promariner.com), for a Complete Selection of Quality Marine Products...**

**Here are just a few:**

- ▶ ProMite Series - Standard Edition Waterproof Marine Battery Chargers
- ▶ ProSport Series - Recreational Sport Fishing & Boating Waterproof Marine Battery Chargers
- ▶ ProTournament Series - Professional Grade Tournament Waterproof Marine Battery Chargers
- ▶ Advanced 4 Step Dry Mount Marine Battery Chargers
- ▶ Battery Maintainers
- ▶ AC Plug Holders
- ▶ Battery Isolators
- ▶ ProSport Cup Holder Inverters
- ▶ Pro Inverters
- ▶ AC to DC Inverters
- ▶ Advanced Regulators
- ▶ Corrosion Control Products
- ▶ Waterproof Marine Binoculars
- ▶ Marine CCTV Color Camera Equipment
- ▶ Gold Plated Fuses and Holders
- ▶ A Complete Selection of Panel Meters and Shunts
- ▶ A Complete Line of Hand Held Test Meters
- ▶ Online Technical Support and Service Support

Visit frequently, we are always adding new products for your boating enjoyment!

---

Professional Mariner, LLC  
200 International Drive  
Suite 195  
Portsmouth, New Hampshire 03801  
TEL: 603-433-4440  
FAX: 603-433-4442  
[www.promariner.com](http://www.promariner.com)

specifications subject to change without notice