

ZAPCO
MODEL AG750
750 WATT
STEREO POWER AMPLIFIER
Owner's Manual

Contents

Symbilink™ Balanced System	2
Key Features	3
Warnings	4
Installation Guidelines	5
Front Panel Layouts	6
Variable Electronic Crossover	8
Variable Bass Equalization	9
Power VS. Distortion	10
System Diagrams	11
Specifications	19
Technical Assistance	20

Symbilink™ Balanced System

The most natural configuration for an audio system in the automobile places the signal source in the dash with the amplifiers located some distance away, usually under the seat or in the trunk of the vehicle. The reality of this arrangement dictates the necessity to make long runs of low level signal cable usually from the front to the back of the car. The electrical environment in an automobile is one that is inherently noisy and filled with conditions that threaten to degrade signal fidelity at every turn. Capacitive loading due to the long cable lengths, the potential for ground loops, alternator charging currents or currents generated by the amplifiers themselves are all factors that induce noise and distortion into the signal cables. By no means is this an ideal situation. Thankfully ZAPCO has found the solution.

SymbiLink™ components convert a standard unbalanced audio signal into the fully balanced domain usually reserved for expensive professional audio equipment found in recording studios or at your local concert venue. After this conversion is made, the audio cabling becomes virtually immune to electrical interference in the surrounding environments and much less susceptible to signal degradation over long cable runs. It is for this reason that balanced signal cables are common in professional or industrial applications. ZAPCO has made this technology available for your car. ZAPCO engineers also discovered that the pulsating D.C. current in the automobile chassis and amplifier power wiring caused a significant amount of low frequency distortion. ZAPCO's balanced SymbiLink technology completely eliminates this distortion.

Key Features

- SymbiLink™ Balanced Inputs
- RCA Unbalanced Inputs
- Two Ohm Stable
- 18 dB Variable Bass Boost Control
- Two Built in Independent Variable Electronic Crossovers
- Bridgeable
- One to Three Channel Capable
- High Current Bipolar Outputs
- Optically Isolated Mosfet Power Supply
- Selectable Auxiliary Output (Highpass / Lowpass or Fullrange)
- Quality ZAPCO Construction
- Designed and Built in the U.S.A.

Warnings

ZAPCO highly recommends that a fuse or circuit breaker be placed within 18" of the battery. Although products have adequate internal protection, it is possible that a pinched power wire between the component and the battery may result in a fire. The protection device should be placed where it can be accessed easily and all wiring should be routed safely and correctly according to the following guidelines: Do not run wiring close to hot or spinning objects.

Always use wire grommets when routing wire through the firewall or any other metal panels.

Make sure that the potential for pinched wiring is avoided by routing all wires away from moving hinges and seats. This also includes brake, gas and clutch pedals, hood and trunk hinges, etc.

Caution:

Continuous exposure to excessive sound pressure levels may cause permanent hearing loss. ZAPCO strongly advises that you use common sense when setting volume levels. If you experience ringing in the ears, it could cause permanent hearing damage!

CAUTION!

When connecting our amplifiers to prewired stock speakers care must be taken that there are no common connections in the speaker wires, i.e. minus to minus or plus to plus connections, as this will cause the amplifier to go into immediate protection or may cause damage to the amplifier. Output connections are not common chassis ground. Please follow the hookup instructions in this owner's manual. Any questions should be directed to your local Zapco dealer or call us at 209-577-4268.

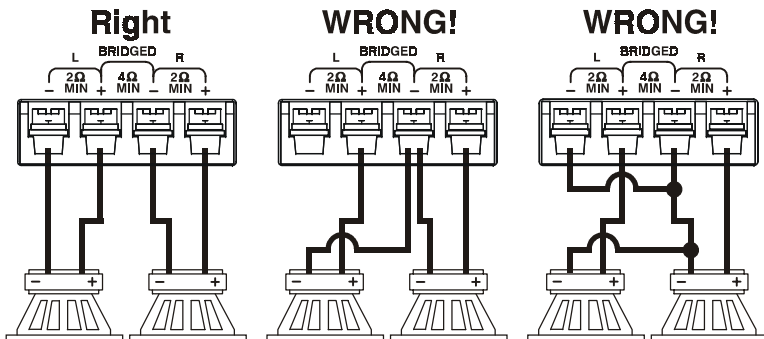

Installation Guidelines

- Mounting the AG750 is easy. Keep in mind the following guidelines:
- The amplifier may be mounted in any direction, on wood, metal or carpet.
- The metal case of the amplifier may be grounded or left isolated.
- The amplifier requires adequate ventilation. Position the amplifier with sufficient surrounding area for proper cooling.
- Keep fan and vent endplates clear for proper internal cooling.
- Keep the amplifier out of the engine compartment and other locations that may cause excessive heat or moisture.
- **Do not mount the amplifier to a subwoofer enclosure or any other place that may have excessive vibration!**

Front Panel Layouts

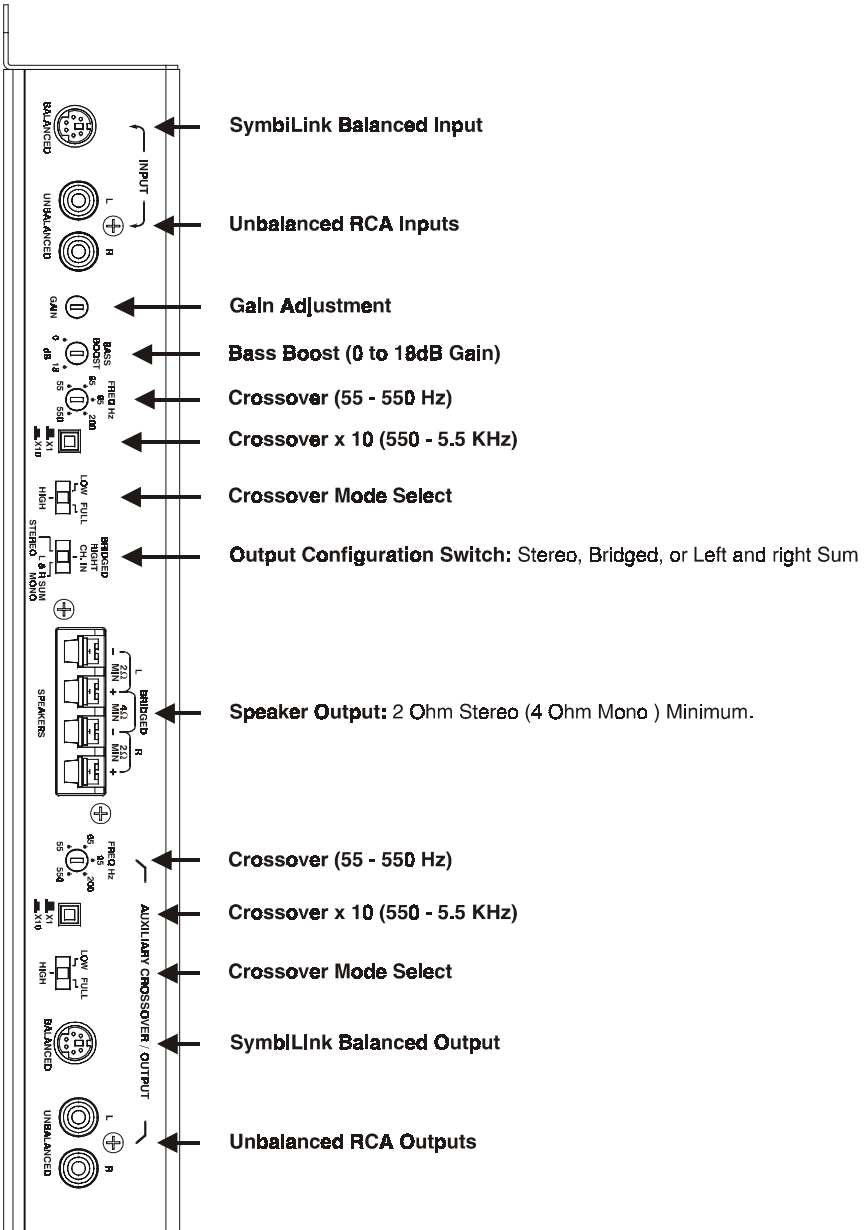

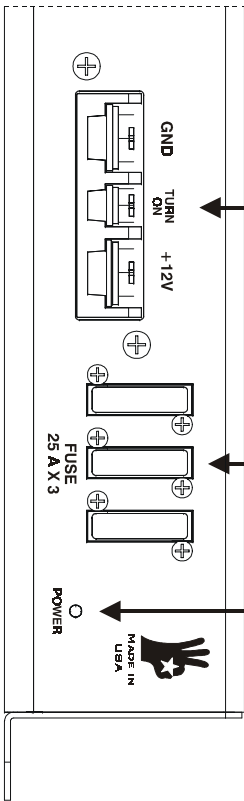

**12V Power Connector
4 Gauge Strongly Recommended
on Ground and + 12 Volts**

Blade Fuses: 25Amps x 3

Power On Light

Variable Electronic Crossover

The AG750 amplifier has 12dB/ octave variable highpass and lowpass crossovers. A front panel switch selects highpass or lowpass mode. The front panel variable control allows continuous frequency selection from 55Hz to 5.5KHz. The chart below shows the response:

Crossover Response Curves

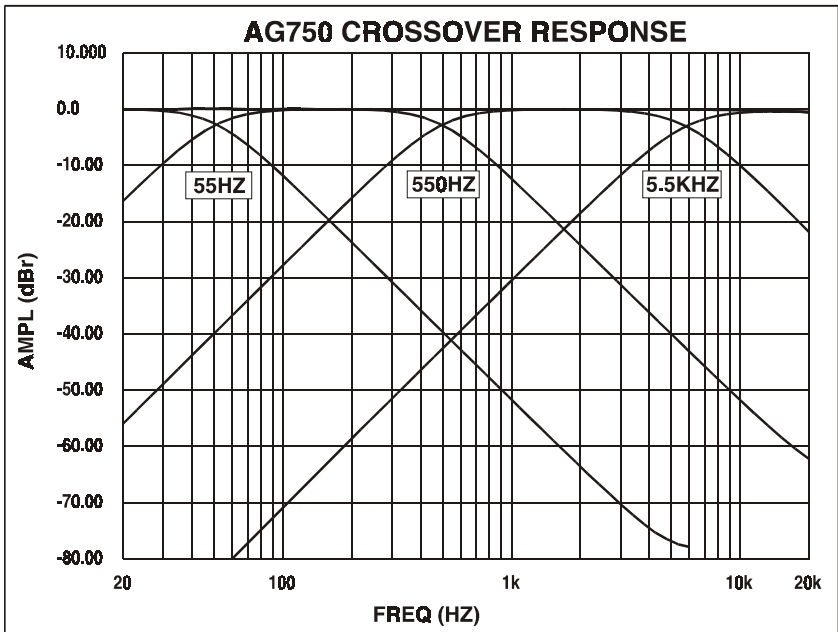

Variable Bass Equalization

The AG750 has variable bass equalization centered at 44Hz. A front panel control adjusts boost from 0 to 18dB. The equalization curves for various control positions are shown in the chart below:

Bass Equalization Curves

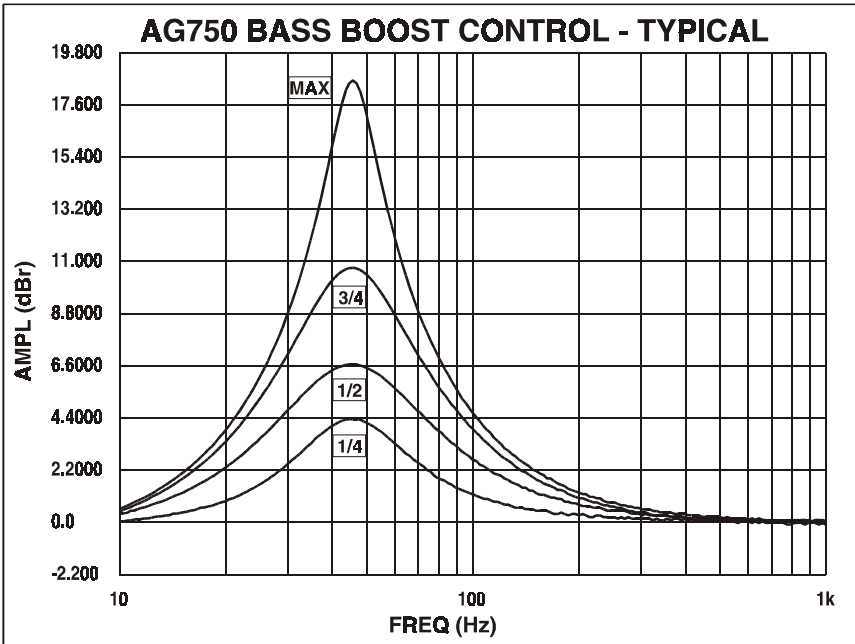

Power VS. Distortion

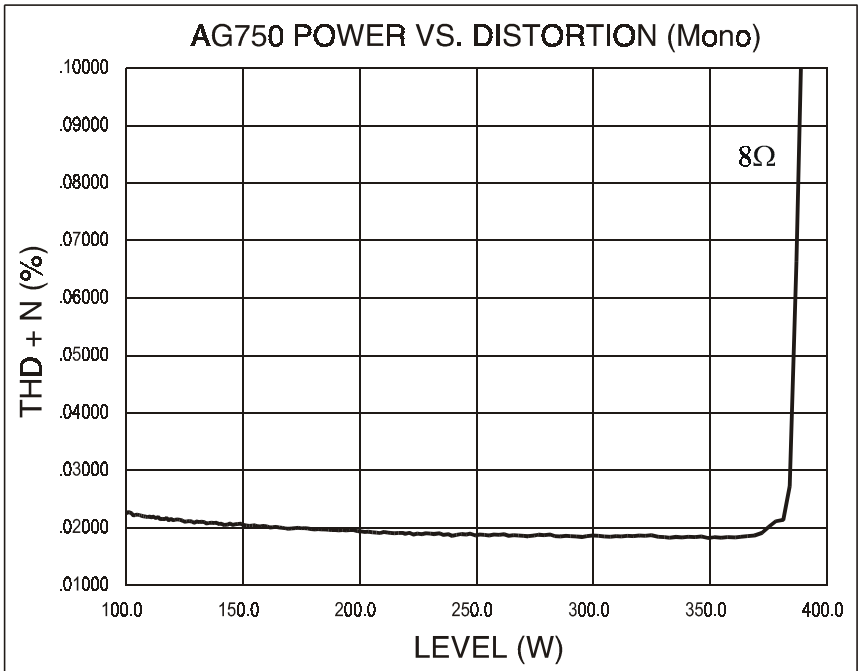

System Diagrams

Basic Full Range System

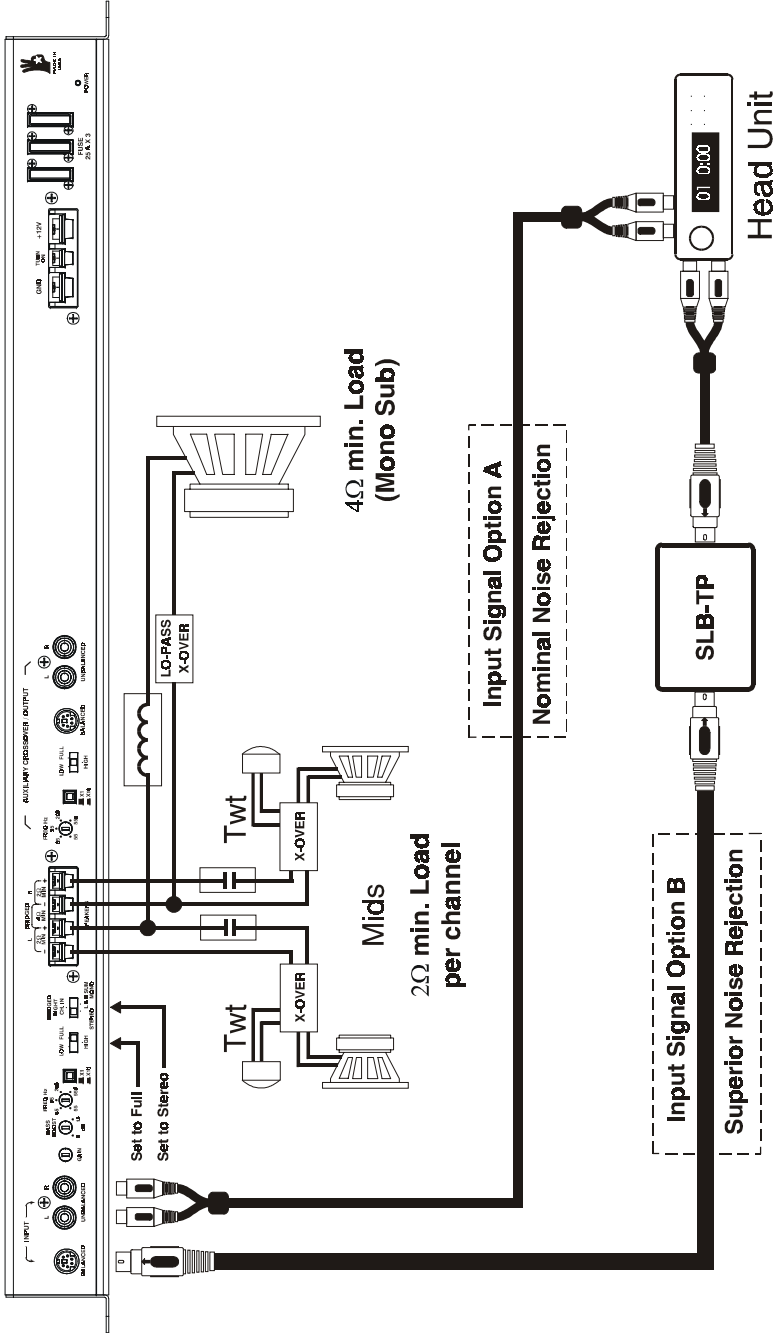

Two Amp System with Sub @ 65 Hz

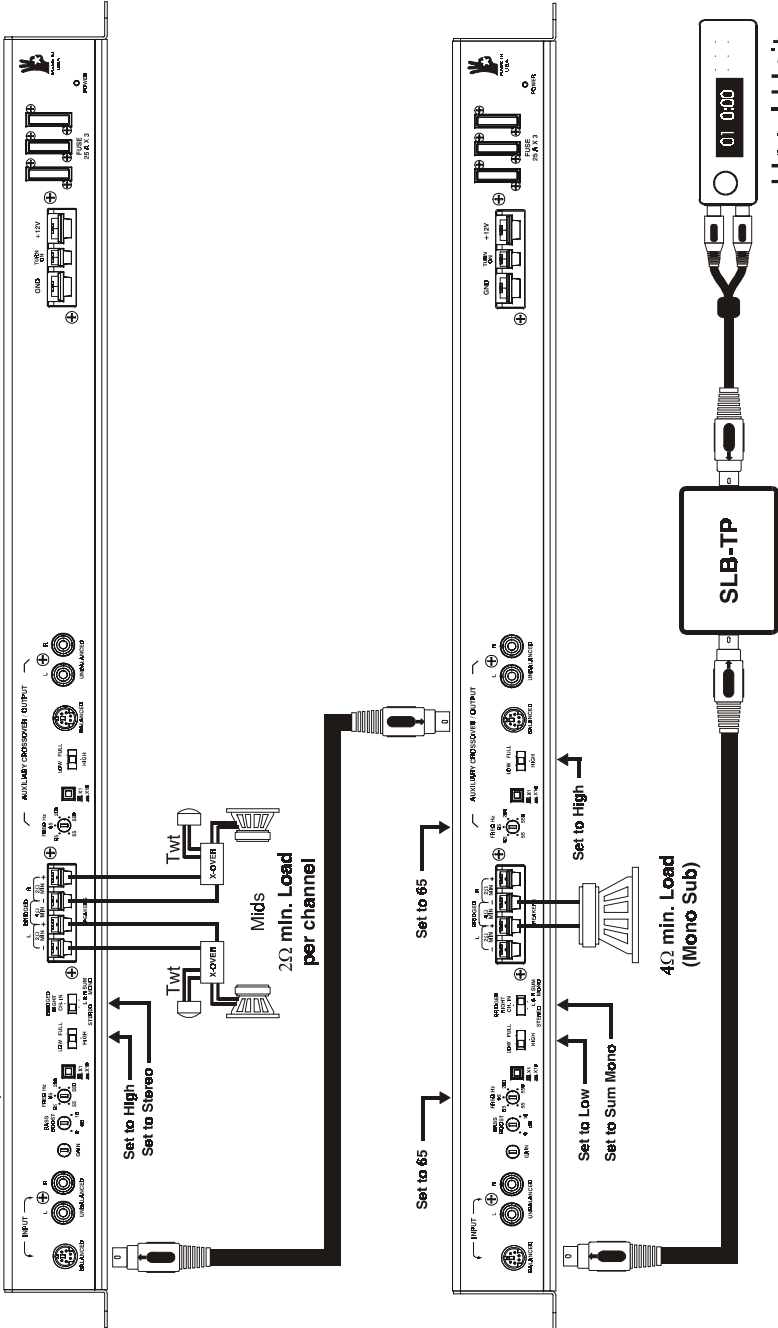

Four Channel Front and Rear W/ Mono Sub

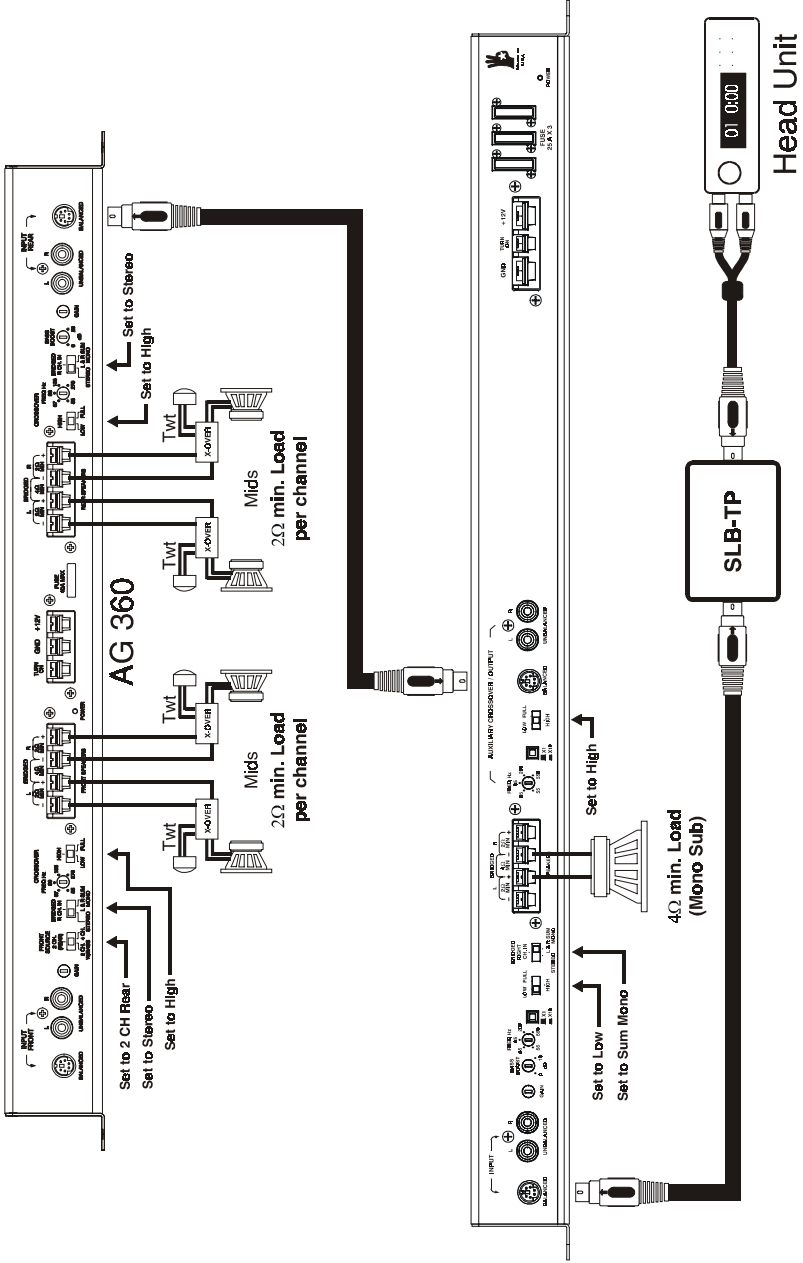

Two Way System W/ Sub Amp and Processor

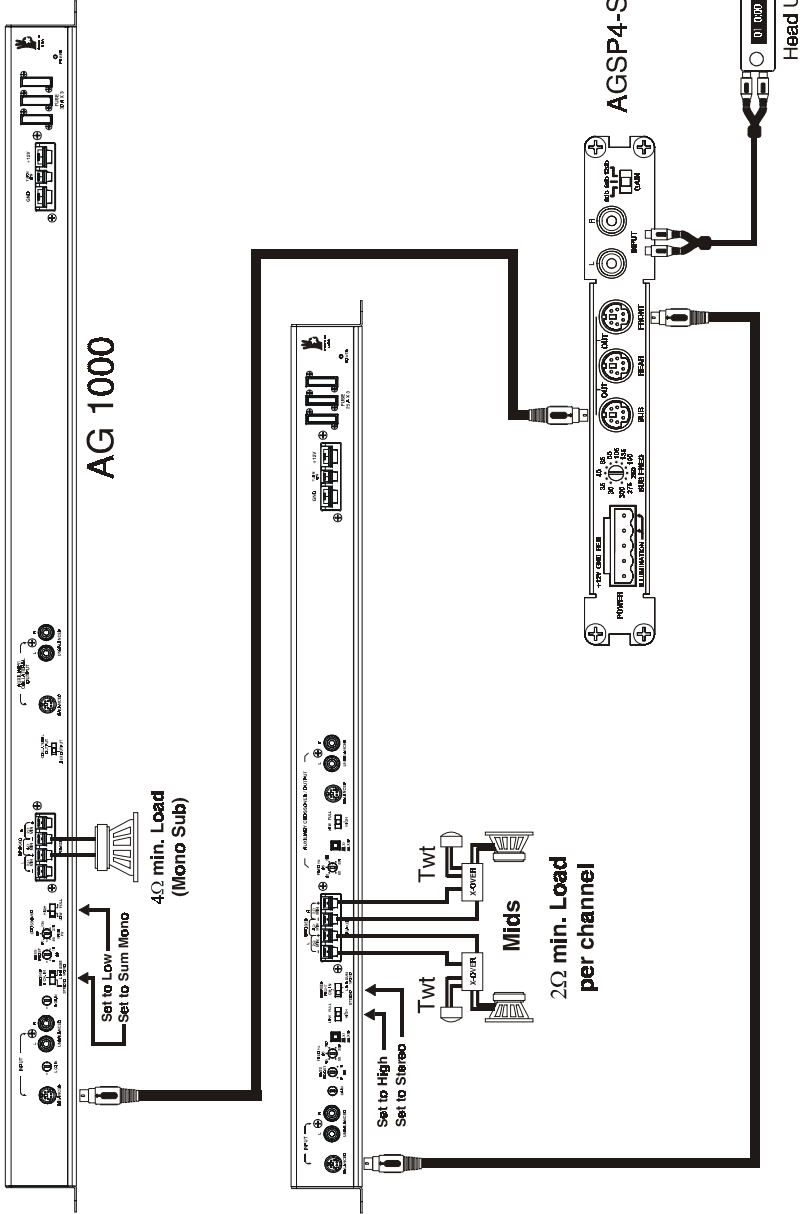

Three Amp with Processor

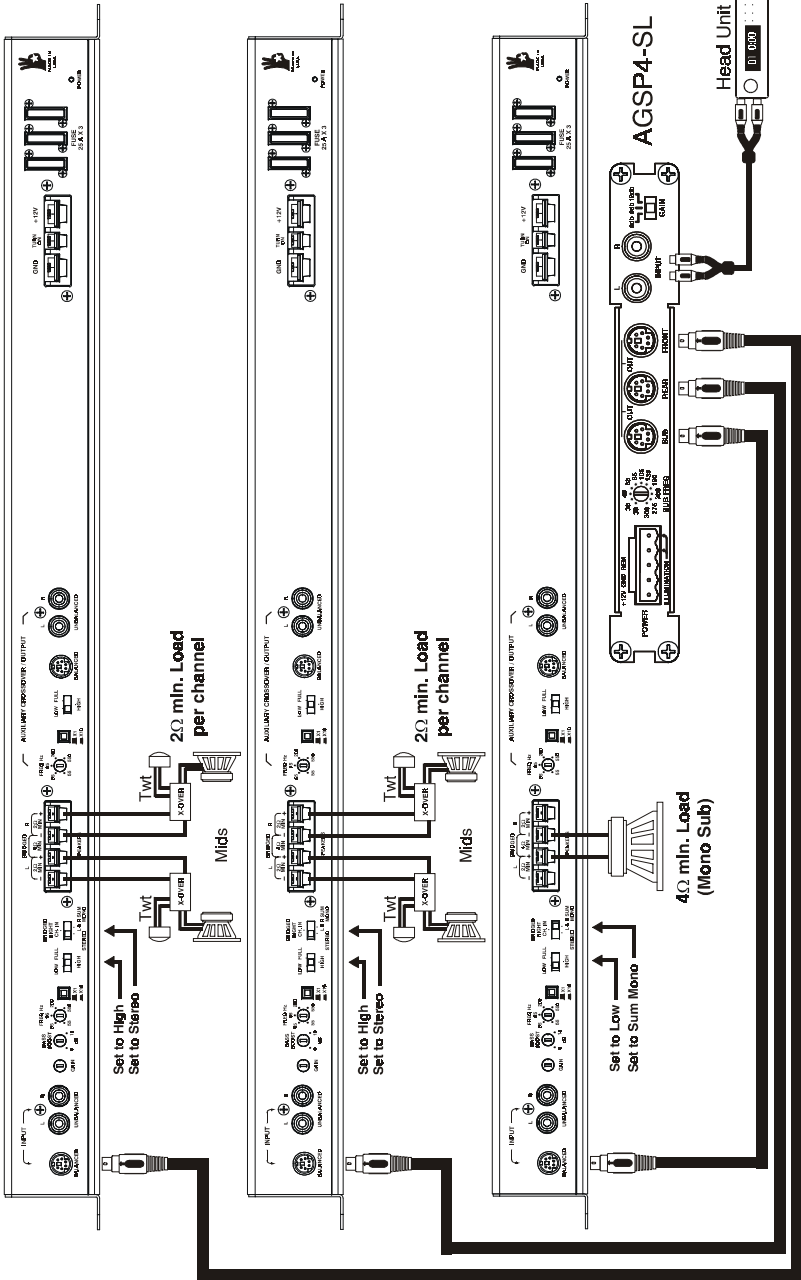

750 Watt / Channel Mid / High Plus 900 Watt Mono Sub

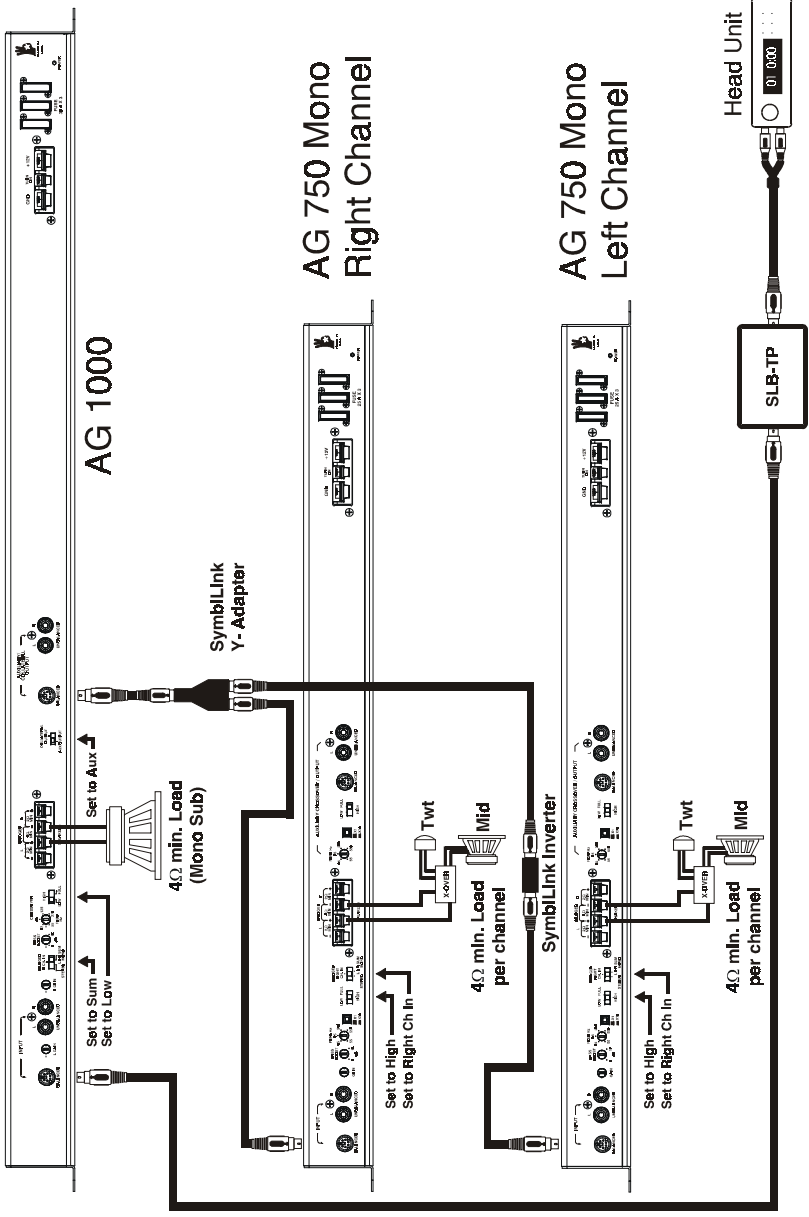

Three Amp System w/ Full Competition Processing

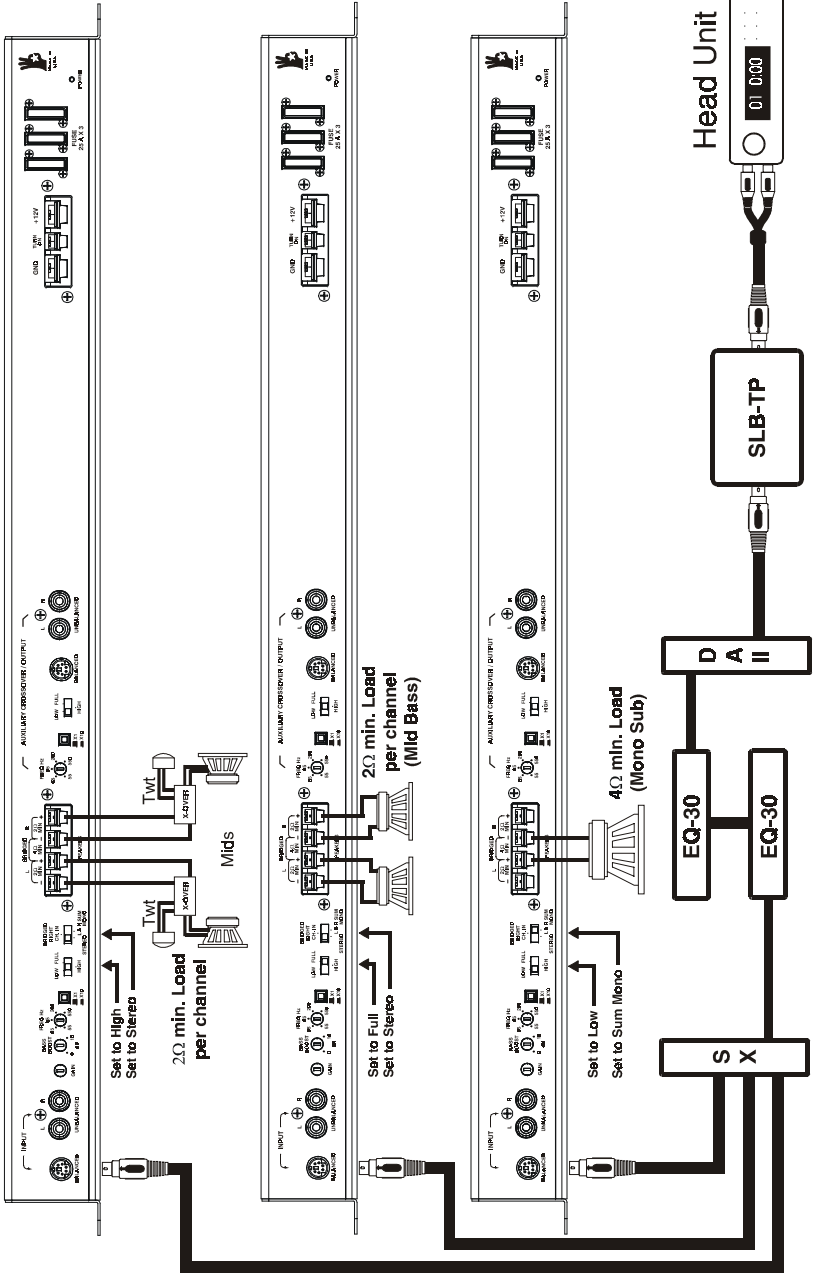

Specifications

Total Power (14.4V @ 1kHz)	Power
Rated Power / Channel	T.H.D.+N
385 watts x 1 @ 8Ω Mono	< .04%
390 watts x 1 @ 8Ω Mono	< .05%
Bridged Mono	
725 watts x 1 @ 4 Ω Mono	< .04%
750 watts x 1 @ 4 Ω Mono	< .2%
Frequency Response	20 – 20kHz, + 0 / - .5dB
S/N Ratio	> 90dB
Transient Distortion (4Ω, 40W)	< .03%
Slew Rate	40 V/μS
Damping Factor	> 1000 @ 4Ω
Input Sensitivity	
Balanced (DIN)	560mV – 5.6V
Unbalanced (RCA)	260mV – 2.6V
Separation	> 60dB
Max. Current Requirements	120 Amps @ 750 watts
Idle Current	1.56 Amps
Dimensions	24.5”L x 7.5”W x 1.95”H

Technical Assistance

Should you experience a problem with your AG750, please contact the dealer that sold you this product. If your dealer is unable to solve your problem, you may contact the factory service department directly.

Phone: (209) 577-4268 Monday - Friday, 8AM - 5PM Pacific Time
FAX: (209) 577-8548

Also, check our web page, www.zapco.com, for tips. You can also e-mail technical help directly from our web page or engineer@zapco.com.

If you need to return this product for repair, please call the factory for a Return Materials Authorization (RMA) number. We will ask you for information that will include your name, return shipping address, daytime phone number, model and serial number, and a detailed description of your problem. A photocopy of your original purchase receipt is necessary to determine warranty status and should also be included. Once we issue you an RMA, please write it in a highly visible area on the package. ZAPCO will not accept any packages that do not have a valid RMA number clearly marked on the outside of the package.

Once you have a valid RMA number, send all repairs to:

A.R.P.A. of America Corp.
D.b.a. Zapco
Attn.: Service Department
413 S. Riverside Drive
Suite D
Modesto, California, 95354

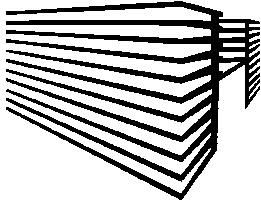

ZAPCO
the Driving **FORCE**

A.R.P.A. of AMERICA CORP.
D.b.a. **ZAPCO**
413 S. RIVERSIDE DRIVE, SUITE D
MODESTO, CA 95354
(209) 577-4268
FAX (209) 577-8548
WWW.ZAPCO.COM

AG750
REV. A
7/99