



REFERENCE SERIES SUBWOOFERS

RW10
RW12

WELCOME

Thank you for buying a DLS Reference subwoofer. The subwoofer must be installed correctly in order to work well. This manual will show you how to install it like a pro. Please read the entire manual before beginning the installation. Install the subwoofer yourself if you feel confident with our instructions and if you have the proper tools. However if you feel unsure, turn over the installation job to someone better suited to it.

The speakers are designed for enclosure mounting. In "open air" installations the power handling capacity is reduced by 30% from the nominal value. We don't recommend "open air" installations for Reference subwoofers.

CONNECTION OF SUBWOOFER

How to connect depends on what type of amplifier you use. The best is to follow the instructions given in the manual for the amplifier. Most amplifiers today have built-in lowpass crossover and possibilities to connect your subwoofer in bridge mode.

Please note that the RW10 and RW12 subwoofers have a 2 ohm impedance, if connected in bridge mode to your amplifier the resulting impedance is 1 ohm. This means that your amplifier must be 1 ohm stable.

Make sure to connect in a way that don't ruin the amplifier. If you have a DLS Ultimate amplifier it's possible to connect the two subwoofers in parallel, these amplifiers are 1 ohm stable.

We also recommend the use of a subsonic highpass filter. This gives a better bass reproduction with less "rumble". In most DLS amplifiers this feature is already built-in.

For wiring use high class speaker wires, min AWG13 (2.5 mm²). For example **DLS SC 2x4**.

RUNNING-IN PERIOD

Allow the speaker to play for at least 15-20 hours. After this time the performance is correct.

WARRANTY SERVICE

This speaker is covered by warranty, depending on the conditions in the country where it is sold. If the speaker is returned for service, please include the original dated receipt with the product.



Technical Assistance

For technical assistance ask the shop where the product was sold or the distributor in your very country. You can always phone the DLS Helpdesk in Sweden + 46 31 840060 or send an e-mail to info@dls.se

Information can also be found on our WEB-site www.dls.se

We follow a policy of continuous advancement in development. For this reason all or part of specifications & designs may be changed without prior notice.

SUBWOOFER ENCLOSURES, GENERAL

Build your enclosure in a stable and airtight material. The best is MDF-board, 19 mm, or particle board, 22 mm. Larger enclosures must have bracing inside to avoid vibrations. The enclosure must be completely airtight. Use sealing compound in all joints, also around the cable terminals. The size of the enclosure is decided by the speaker data.

SEALED ENCLOSURES

Sealed enclosures are easy to build. The size is not critical, but it can't be too small. The speaker data such as Fs, Qts, Vas and X-max decides the size of the enclosure.

Large speakers need larger boxes. Two speakers need a box of the double size etc. The enclosure must be completely airtight. A sealed enclosure should be filled with acoustic wool up to 75 - 100%.

A sealed enclosure has a lower efficiency than vented enclosures but they can handle high power and is easy to build. A subwoofer in a sealed enclosure creates a tight bass suitable for the audiophiles listening to classical music, jazz and soft rock. RW10 and RW12 are designed for use in sealed enclosures.

IMPORTANT!

Think of the speaker weight when you do your install. Use heavy bolts when fastening the sub to the enclosure baffle.

ENCLOSURE PLACING IN DIFFERENT TYPES OF VEHICLES

In **small vehicles** like VW Golf, Peugeot 306 and similar the bass box should be installed with both speaker and port directed backwards. Alternatively both speaker and port can be directed upwards. This way of mounting is valid for all types of vehicles where the trunk is incorporated with the inner compartment.

In **sedan vehicles** with the passenger compartment separated from the trunk, the enclosure should be installed with both speaker and port directed towards the rear seat. Some cars have an opening in the middle of the rear seat for loading skis etc. You can install the enclosure behind this opening and direct speaker or port through this opening. There must be some free space in front of the port, (between the rear seat and the port opening).

In **large vehicles** like station wagons the best sound is achieved with the enclosure installed behind the rear seat with both speaker and port directed backwards. Alternatively you can install the enclosure on one side of the luggage compartment.

ABOUT THE RECOMMENDED ENCLOSURES

The performance of these recommended enclosures will vary from vehicle to vehicle. It is more difficult to get a tight and well defined bass in a SEDAN vehicle because of the tightness between trunk and interior. In most cases the recommended enclosures on next page are the best choice.

- The given enclosure volume is the inner volume.

- Volumes occupied by speaker and ports have already been added to the given enclosure volumes so don't add any more volume.



DLS Svenska AB

P.O. Box 13029

SE-40251 Göteborg, Sweden

Tel: +46 31 840060

Fax: +46 31 844021

E-mail: info@dls.se

www.dls.se

Technical specifications for DLS Reference RW10 & RW12

	RW10	RW12
Size	25 cm (10")	30 cm (12")
Impedance	2 ohm	2 ohm
Nom. power (RMS)	250 W (max 500)	250 W (max 500)
Freq. range	25 Hz - 2 kHz	20 Hz - 2 kHz
Sensitivity	86,5 dB	87 dB
Voice coil diameter	50 mm (2")	50 mm (2")
Re	1,9 ohm	1,9 ohm
Voice coil inductance, 1 kHz	0,89 mH	0,89 mH
BL product	7,8	8,1
X-max	+9 mm (0,35")	+9 mm (0,35")
Suspension compliance CMS	346	248
SD- Effective piston area	346 cm ²	511 cm ²
Resonant freq. (Fs)	28,8 Hz	28,5 Hz
Vas (liters)	58	90
Vas (ft ³)	2,05	3,17
Qms	7,17	6,87
Qes	0,49	0,65
Qts	0,46	0,59
Cone material	Polypropylene	Polypropylene
Magnet weight	47 oz	55 oz
Magnet diameter	5,9" (150 mm)	5,9" (150 mm)
Installation depth	5,9" (150 mm)	6,5" (165 mm)
Mounting hole	9,45" (240 mm)	11" (280 mm)
Outer diameter	10,82" (275 mm)	12,6" (320 mm)
Weighth	9,9 lb (4,5 kg)	12,1 lb (5,5 kg)

RECOMMENDED ENCLOSURE RW10

Sealed enclosure:

Wiring : 2 ohm
 Volume : 18 / 0,64 (litre / ft³)
 Damping : Acoustic wool
 F3 : 54 Hz

Outside box dimensions:

Width : 450 mm (17,7")
 Height : 340 mm (13,4")
 Lower depth : 233 mm (9,17")
 Upper depth : 133 mm (5,24")
 Material : MDF 19 mm (3/4")

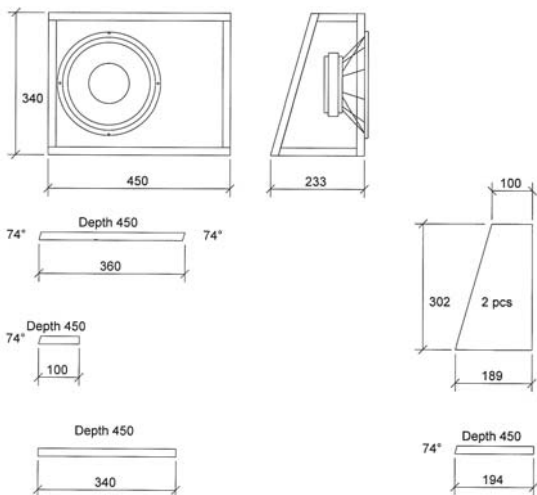
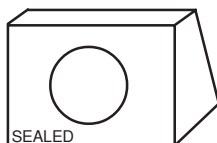

Technical drawing for an 18 litre enclosure.

The RW10 works well in an 18 litre sealed enclosure. This is a drawing for the 18 litre box and the separate boards needed to build a suitable enclosure.

RECOMMENDED ENCLOSURE RW12

Sealed enclosure:

Wiring : 2 ohm
 Volume : 28 / 0,99 (litre / ft³)
 Damping : Acoustic wool
 F3 : 56 Hz

Outside box dimensions:

Width : 520 mm (20,47")
 Height : 360 mm (14,2")
 Lower depth : 270 mm (10,6")
 Upper depth : 170 mm (6,7")
 Material : MDF 19 mm (3/4")

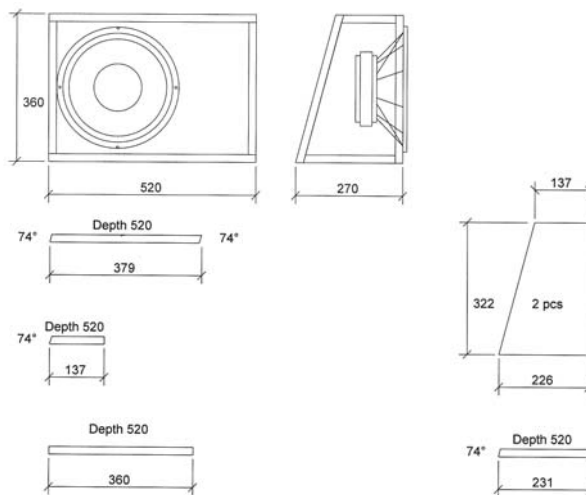
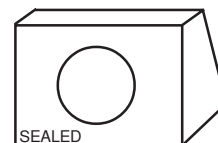

Technical drawing for a 28 litre enclosure.

The RW12 works well in a 28 litre sealed enclosure. This is a drawing for the 28 litre box and the separate boards needed to build a suitable enclosure.

CALCULATE YOUR OWN ENCLOSURE

Box volumes:

When calculating the inner volume of an enclosure you just multiply the width (W) x height (H) x depth (D). Use measures in dm and you will get the answer in liters.

A trapezoid box is calculated as this:

$$\text{Vol} = \text{width (W)} \times \text{height (H)} \times \frac{\text{upper depth (UD)} + \text{lower depth (LD)}}{2}$$

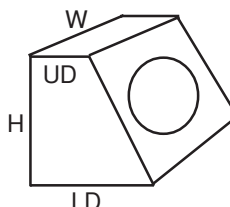

Be sure to measure the inside dimensions.