

KICKER[®]

L5 Technical Manual



Features

- **Mica Filled Polypropylene Cone** A high performance cone that lives up to the Solo-Baric® standard. Any normal cone would crumble under the stress that the Solo-Baric® L5 motor structure puts on the cone. This will give you deeper and stronger bass at higher listening levels with less distortion.
- **Kicker engineered rear cone brace** In order to keep up with the demands on the cone at extreme listening levels, the rear brace has been redesigned and strengthened to reduce the cone flex at these listening levels. The brace works in conjunction with the other components of the cone to insure that cone flex does not decrease the output of the woofer.
- **Increased Surround Radius** In order to achieve high SPL, the woofer needs to have an extreme Xmax (the distance the woofer moves in one direction). In order to do this, the woofer needs a large enough surround that will allow the cone to reach Xmax while handling the stress of doing so. The Solo-Baric® L5 borrows surround technology from it's brother the L7 and handles this requirement with ease.
- **WARG (Wrap Around Gasket)** Instead of using cork gaskets, which can separate, the new Solo-Baric® L5s have a one piece gasket that wraps around the front and back of the mounting flange. It is more durable and ergonomically pleasing to the eye. The previous cork gaskets could tear off or if you were transplanting the speaker into another box, they could stay adhered to the old box causing you to order another gasket. These problems are eliminated with the new rubber gaskets. They not only look better, but also function better by eliminating the chance for air leaks.(provided the box is built correctly!) We still recommend if you are carpeting the box, to cut away any carpet that is under the woofer mounting flange.
- **SSD (Spun Spoke Design)** The basket not only looks impressive, but it is extremely functional. This stamped steel basket provides a solid foundation for the motor assembly insuring that all the parts work together in harmony and prevent shifting or misalignment. Without a solid foundation, the speaker's various parts could shift under extreme excursion causing premature failure and add unwanted noise to the music. If misaligned, the voice coil could rub the inner wall of the motor structure and thus exposing the bare windings, which would cause speaker failure. The same thing happens if the coil former rubs the pole-piece. The damaged former exposes the windings causing speaker failure. When other speakers are pushed to their limits they tend to make noises that add coloration to the music. When you're LIVIN' LOUD you only want to hear the music the artist intended you to hear, not a bunch of unwanted ringing.
- **Perimeter Venting** Without the perimeter venting along the side of the speaker, hot air would be trapped in with the voice coil. This will cause the structure to heat up quicker and cause power compression, which results in decreased output, as well as shorter speaker life. Perimeter venting causes a vortex cooling effect around the coil which exchanges the hot air around the voice coil for cooler air outside the speaker. It also releases pressure from under the spider to allow the speaker to work in a more linear fashion. All of this translates into cooler operating temperatures which will allow the speaker to sound and perform better.

Features cont.

- **Blackened One Piece Uniplate™ with Vented Hyper-Extended Pole**

1. Provides enhanced heat transfer for cool operation and maximum power handling. The heat is transferred from the pole piece to the back plate, effectively acting like a radiator in an engine. This lowers the operating temperature of the voice coil. **Note: The increase in temperature increases the impedance of the speaker.** This results in lower output and is referred to as Power Compression.

2. Reduces non-linear magnetic fields around the voice coil gap for superior cone motion control. The extended pole assures the voice coil is always in the magnetic field when moving peak to peak. When the speaker reaches its Xmax, the voice coil is still in the gap between the pole piece and magnet structure due to its extended pole-piece.

3. Releases pressure under ISD for freer cone motion and enhanced low frequency response. Air trapped under the ISD is forced out through the pole-piece to allow the cone to move freely. Heat and pressure build up under the ISD and need to be released to allow the speaker to function properly.

- **High-Temp Kapton® Voice Coil Former** Heat is the primary enemy to the life of a speaker, which is one of the reasons we use Kapton® voice coil formers. Kapton® is a man-made product that is light, durable and heat-resistant. The Kapton® former acts as an insulator to keep the heat of the voice coil from breaking down the adhesive that connects the voice coil to the cone. During high excursion and prolonged exposure to heat, the Kapton® former holds its shape and does not expand or contract. As a bonus, Kapton® is also a very quiet material during operation and does not discolor the music by adding unwanted sound

- **ISD (Inverted Structural Dome™)** Kicker was one of the first companies to switch to the Inverted Structural Dome. We have designed a cone with a groove for the ISD to lock into, further adding strength to the structure. When a cone reaches its peak it wants to buckle because its momentum keeps it moving out. The ISD provides structural support for the cone to resist buckling. NOTE: When the cone buckles, the output of the woofer decreases. Therefore, the ISD is not just a cosmetic thing, it is an integral part of the woofer to maintain its maximum performance.

- **Stitched Surround** A signature of KICKER woofers has always been the stitched surround. It prevents the surround from separating from the cone at high excursions. When the woofer is moving back and forth it puts a lot of strain on the adhesive that is holding the surround to the cone and often causes the two to separate. Stitching the surround to the cone eliminates this from happening. *If stitching were inexpensive, everybody would do it!*

- **Dual Ultra-Length Voice Coils** A speaker can obtain extreme Xmax only when the voice coil is long enough and can sustain the stress. Dual voice coils give the installer the option of several different wiring configurations compatible with any amplifier.

- **Sleeved High-Power Tinsel Lead Wires** Resist lead breakage and power robbing resistance losses under demanding conditions. When a speaker is being pushed to its limits there is a lot of strain being put on the leads, especially on high performance woofers like the Solo-Baric® L5. Sleeving tinsel leads help strengthen them to resist breakage.

- **Spring-Loaded Nickel Plated Terminals** On a High Performance speaker like the Solo-Baric® L5, you would expect nothing less than a High Performance terminal. They allow the installer to use the maximum gauge wire to minimize power losses for the ultimate Ground Poundin' system.

L5 Cutaway View

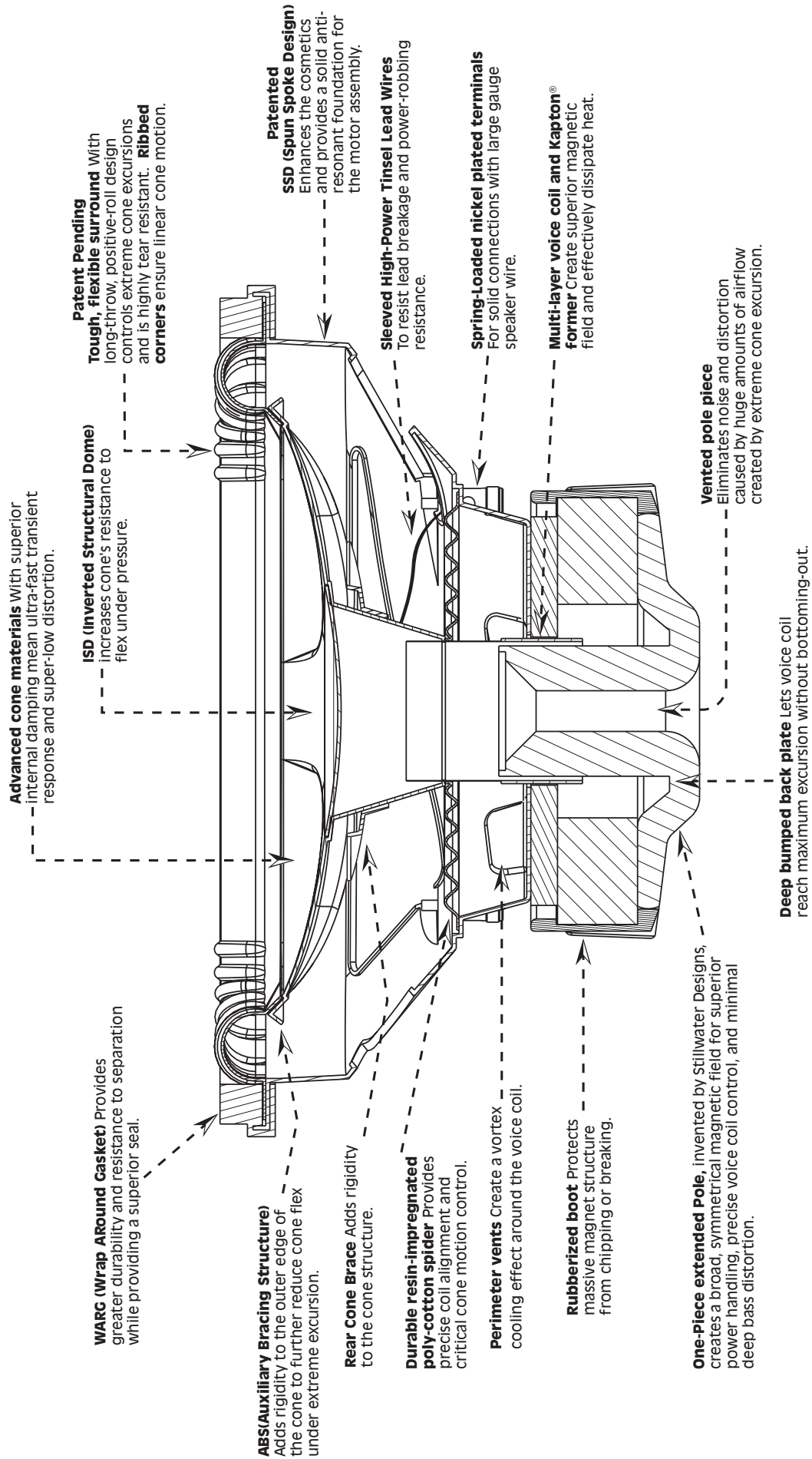

Thank you for your support of Kicker products, and especially our Solo-Baric® L5 (patent pending) square subwoofers. The Solo-Barics® SL5s are truly unique products in a world of round subwoofers. Our technical and R&D staffs have designed some extreme enclosures beyond the small sealed boxes Solo-Barics® are famous for. They have unleashed the awesome capabilities of the L5s.

In this paper we will explore some applications for the Solo-Baric L5 complete with box drawings and cut sheets plus some important information regarding the break-in period for this ground-breaking speaker.

Important Break-In Information

Due to the complex nature of the Solo-Baric L5s they require a little extra time to break-in. Especially in sealed enclosures, break-in is a must in order for woofers to produce optimum low bass response. Due to the high performance suspension system incorporated in the Solo-Barics® they are very stiff "out of the box". Approximately two weeks of daily playing will allow the suspension to break-in and reach its optimum equilibrium. The "broken-in" sub will exhibit stronger bass performance, smoother response, and greater low bass extension.

For those of you with more sophisticated audio equipment, the Solo-Barics can be broken-in on the test bench overnight with the following procedure.

Solo-Baric Freeair Break-in Procedure

1. Connect the speaker to a power amp of about fifty watts or more. The speaker should not be mounted in any enclosure - just freeair. *Please make sure it will not walk off the bench while it is playing!*
2. Connect an audio generator to the input of the power amp, and adjust the generator to approximately 45Hz for the S8L5, 35 Hz for the S10L5, 30 Hz for the S12L5, and 20 Hz for the S15L5.
3. Now adjust the gain on the amplifier and generator so that the cone is moving to Xmax. This can be determined visually by looking at the "blur depth" of the logo on the ISD. A close approximation will do. On the S8L5 this will be about 3/4", on the S10L5 about 1", on the S12L5 about 1", and on the S15L5 about 1 1/4".

NOTE: Keep in mind that as the speaker is used under normal conditions the break-in will continue, so if you don't have time for the complete break-in period the speaker will still break-in itself under normal usage.

Sealed Enclosure Applications

The Kicker Solo-Baric SL5 woofers are designed to give more output than an equivalent round speaker. The SL5 is amazing when used in the recommended sealed boxes. These sealed enclosure SQ recommendations will give the smoothest response with the most energy at really low frequencies, around 20 to 30 Hz.

The recommended **Compact** sealed boxes are in line with our traditional Solo-Baric enclosures. They deliver massive amounts of high impact bass and can be driven with punishing levels of amplifier power.

One of the benefits of the L5-Series high performance suspension system is that the Solo-Barics can operate in larger sealed enclosures for ultra sound quality (SQ) applications without significantly sacrificing their power handling. This extra bass extension and smoothness can be obtained by simply using a larger sealed enclosure. The box can be "sized up" all the way up to the maximum SQ enclosure, which has a very flat response, with greatly extended sub bass.

Solo-Baric L5 series woofers also perform well in any sealed enclosure between the **Compact** and **SQ** sizes. These systems will exhibit some benefits of both (high impact and low extension) generally sounding more like the box to which they are most closely sized.

Recommended Enclosures - Moderate Efficiency -

Model	Compact	SQ
S8L5	.33 cu.ft. Power Handling = 300W <i>9.34 l</i>	.75 cu.ft. Power Handling =300W <i>21.24 l</i>
S10L5	.66 cu.ft. Power Handling = 450W <i>18.69 l</i>	1.0 cu.ft. Power Handling =450W <i>28.32 l</i>
S12L5	.88 cu.ft. Power Handling = 600W <i>24.92 l</i>	2.0 cu.ft. Power Handling = 600W <i>56.64 l</i>
S15L5	1.5 cu.ft. Power Handling = 750W <i>42.48 l</i>	6.0 cu.ft. Power Handling = 750W <i>69.92 l</i>

NOTE: All sealed boxes should be 50% filled with loose polyfil. Allow about two weeks break-in time for the Solo-Barics to reach optimum low bass performance.

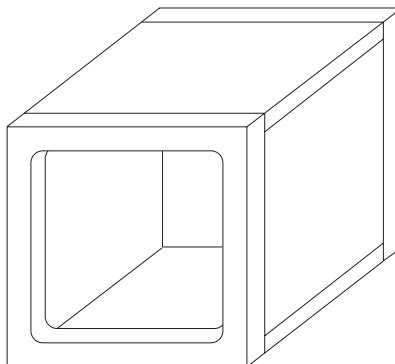

Characteristics of Sealed Enclosures

The most basic and simple of all speaker enclosures is the sealed box or acoustic suspension design.

The acoustic suspension design has several advantages; it is easy to build, easy to tune and offers high power handling, tight response and extended low end output. Acoustic suspension enclosures produce lower bass because they roll off at 12 dB per/octave. Cone motion is better controlled at all frequencies because of the constant pressure on the back side of the cone. This enables you to run more power to the woofer. They are called acoustic suspension enclosures because the air inside the box acts like a viscous brake to control the woofer. That is why the box needs to be sealed tight. If there are any air leaks the woofer cannot function properly because there is very little force being exerted back on the woofer.

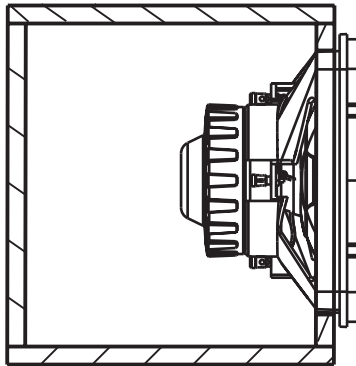

Pros

- 1 - High power handling capability
- 2 - Extended low frequency response and smooth roll off (12 dB/octave).
- 3 - Excellent transient response.
- 4 - Tolerant of minor enclosure size variations.
- 5 - Easiest enclosure to build.

Cons

- 1 - Not as efficient as other designs.

Sealed Box Response Curves

S8L5 .33cu.ft./ .75cu.ft.

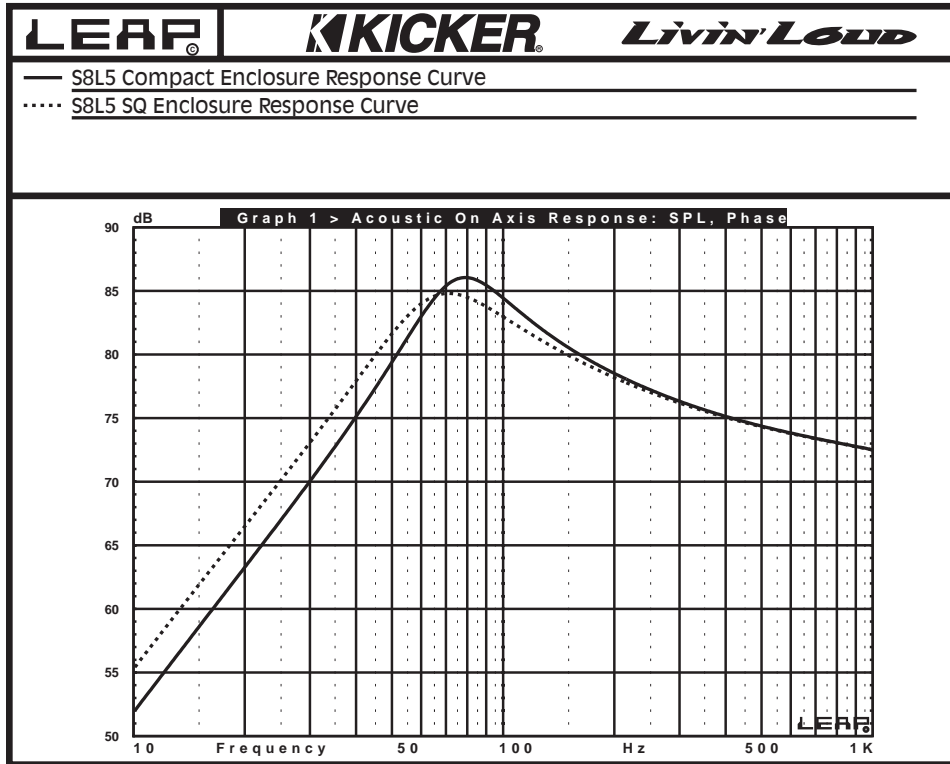

S10L5 .66cu.ft./1.0cu.ft.

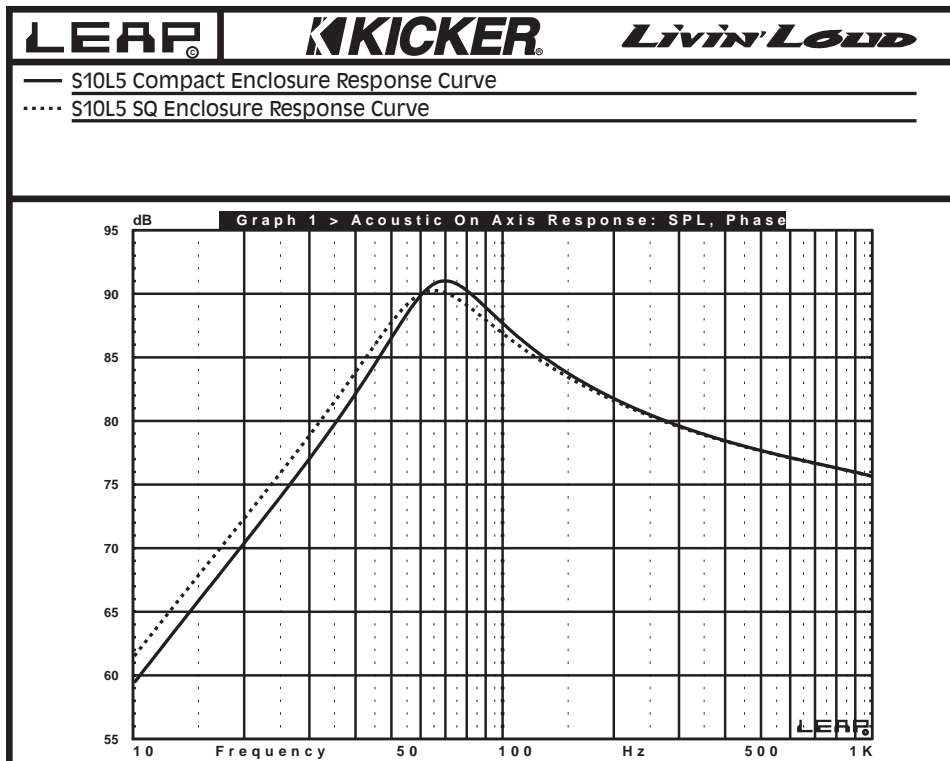

Sealed Box Response Curves

S12L5 .88cu.ft./2.0cu.ft.

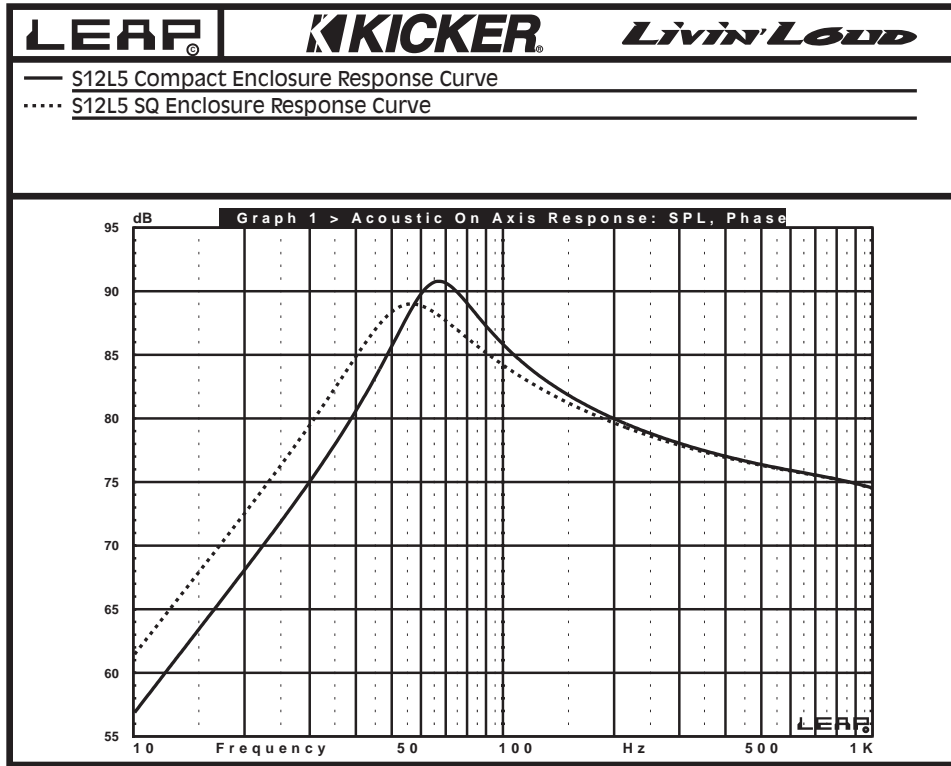

S15L5 1.5cu.ft./6.0cu.ft.

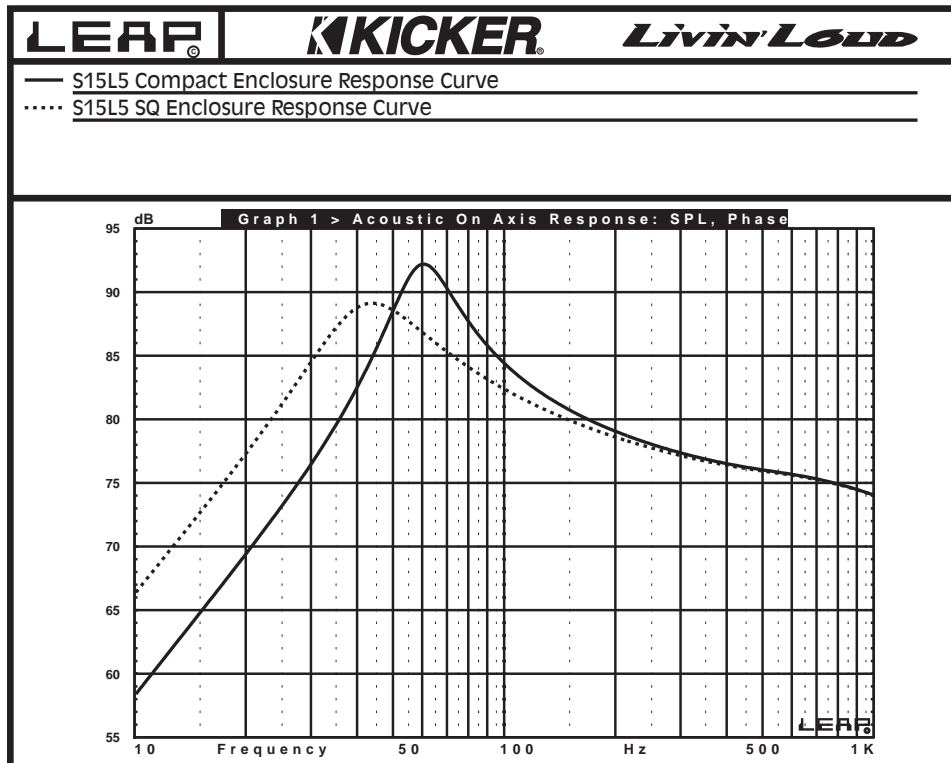

Ported/Vented Enclosure Applications

Ported Solo-Barics incorporate massive slot loaded ports with ultra low air velocity for ground pounding street bass that will make your hair stand on end (if you have any left)! These are the enclosures of choice for outrageous street bass and high performance SPL contests.

The following chart shows three recommended ported enclosures for each Solo-Baric driver.

Compact has increased bass efficiency over a sealed enclosure, yet can still fit in tighter applications. It is the smallest design that will work well for each woofer. Although it is the smallest ported enclosure the output from 30 to 80 HZ will be considerably higher than that of a sealed box. This smallest vented design is for places where you can only give up the room normally taken up by two L5s in the normal small sealed boxes. The two other ported designs have proportionately more output in this region.

Street Bass is a medium sized enclosure that will kick out bass that can be heard for blocks away. And it does go LOW!

Finally, **SPL / Deep Bass** is a large enclosure that has it all. It is high efficiency and will deliver the output needed to win SPL contests, yet low frequencies go all the way down to the basement - with power that will shake the foundations! We're talking truly awesome.

If space is not at a premium and you want to get the most from your Solo-Baric L5, try one of these designs. You won't be disappointed. **Note: You must add the port volume to the volume of the box! See the cut sheets.**

Recommended Ported Enclosure – High Efficiency –

Model	Compact	Street Bass	SPL / Deep Bass
S8L5	.66 cu.ft. + port; 1.5x9.5" port, 19.25" long Power Handling = 300W	.8 cu.ft. + port; 1.75x9.5" port, 19.75" long Power Handling = 300W	1.0 cu.ft. + port; 2x9.5" port, 21.25" long Power Handling = 300W
S10L5	1.25 cu.ft. + port; 2.5x11.25" port, 19.75" long Power Handling = 425W	1.75 cu.ft. + port 2.75x11.25", port 17.75" long Power Handling = 450W	2.25 cu.ft. +port; 3x11.25" port, 18" long Power Handling = 450W
S12L5	1.75 cu.ft. + port; 2.5x13.25" port, 22.5" long Power Handling = 600W	2.5 cu.ft. + port; 2.5x13.25" port, 16.5" long Power Handling = 600W	3.25 cu.ft. + port; 3x13.25" port, 14.5" long Power Handling = 600W
S15L5	3.0 cu.ft. + port; 2.5x16.25" port, 19.5" long Power Handling = 750W	4.5 cu.ft. + port; 3x16.25" port, 14.75" long Power Handling = 750W	6.0 cu.ft. + port; 3.5x16.25"port, 13.75"long Power Handling =750W

NOTE: The use of a subsonic filter is necessary to insure the life of the woofer in a ported enclosure.

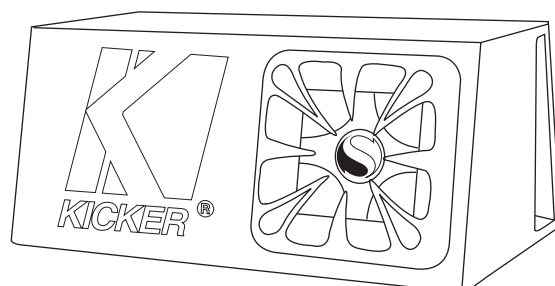

Characteristics of Vented Enclosures

A vented enclosure is not much more complex than a sealed box. It consists, basically, of a box with a hole in it. However, despite its simple design, vented boxes are considerably harder to get good performance from than sealed boxes - although many times the extra effort can be worth it.

The vent in the enclosure interacts with the volume of air in the cabinet and with the driver to help increase output and reduce cone excursion at and around the tuning frequency. In fact, at box tuning, almost all the bass is produced by the vent - NOT the woofer.

The trick in building a vented box is to get the right size enclosure and the right size vent. You can't be too far off on either of these factors or your speaker's performance will suffer. In particular, using a too-small box or a too-high vent tuning frequency can eliminate bass instead of increasing it. Porting a sealed box that is too small usually does nothing to improve frequency response. The vent placement within the enclosure is also important. You must leave at least the equivalent of the vent's diameter between the vent and any inside wall. For example, you would not place a vent with a 3" diameter within 3" of any wall. The same is true for clearance between the vent opening and the bottom of the enclosure.

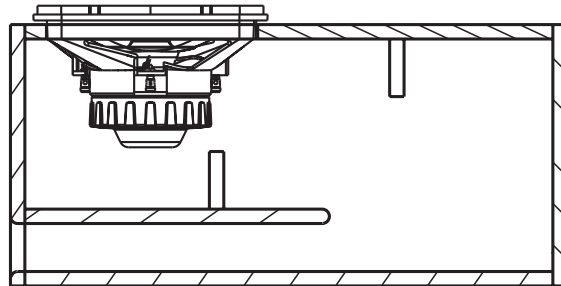

Pros

- 1 - Reduced cone excursion and reduced distortion around vent tuning.
- 2 - Increased output capabilities around vent tuning.
- 3 - Vented boxes give you that extra "Bump" that is preferred in certain types of music.

Cons

- 1 - Total loss of cone control below vent tuning, which can result in high distortion and driver mechanical failure.
- 2 - Midrange sound coming from inside the box through the vent can produce unpleasant sound coloration.
- 3 - Vented enclosures are more sensitive to changes such as temperature, humidity and driver fatigue.
- 4 - Enclosure design is more complex and the enclosure itself must be more solidly constructed because internal pressure at frequencies around vent tuning can be nearly twice as high as a sealed enclosure.
- 5 - Vented enclosures usually don't sound as fast as sealed boxes because of the resonant effects of the vent tuning, which is always slightly out of phase with the driver's output.

Vented Box Response Curves

S8L5 .66cu.ft./ .80cu.ft./1.0cu.ft.

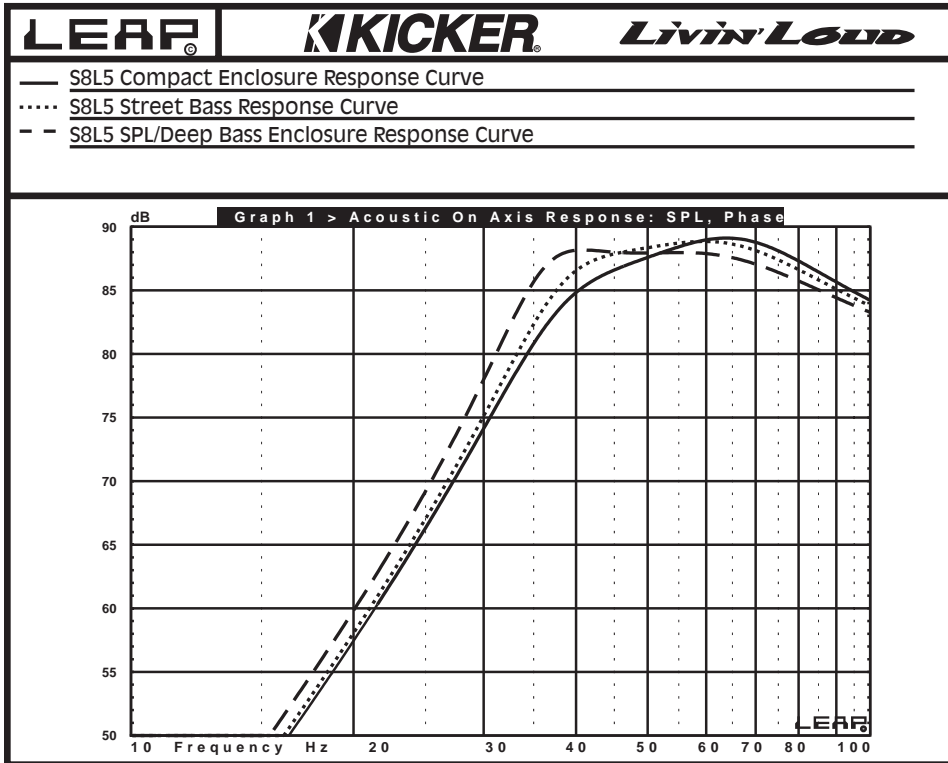

S10L5 1.25cu.ft./1.75cu.ft./2.25cu.ft.

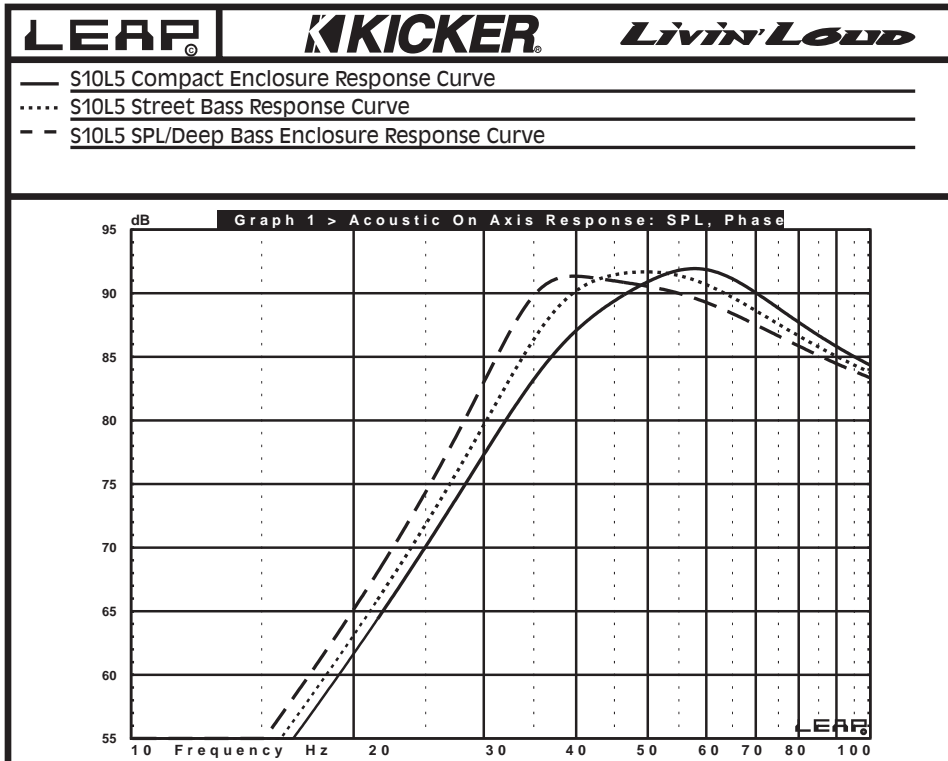

Vented Box Response Curves

S12L5 1.75cu.ft./2.5cu.ft./3.25cu.ft.

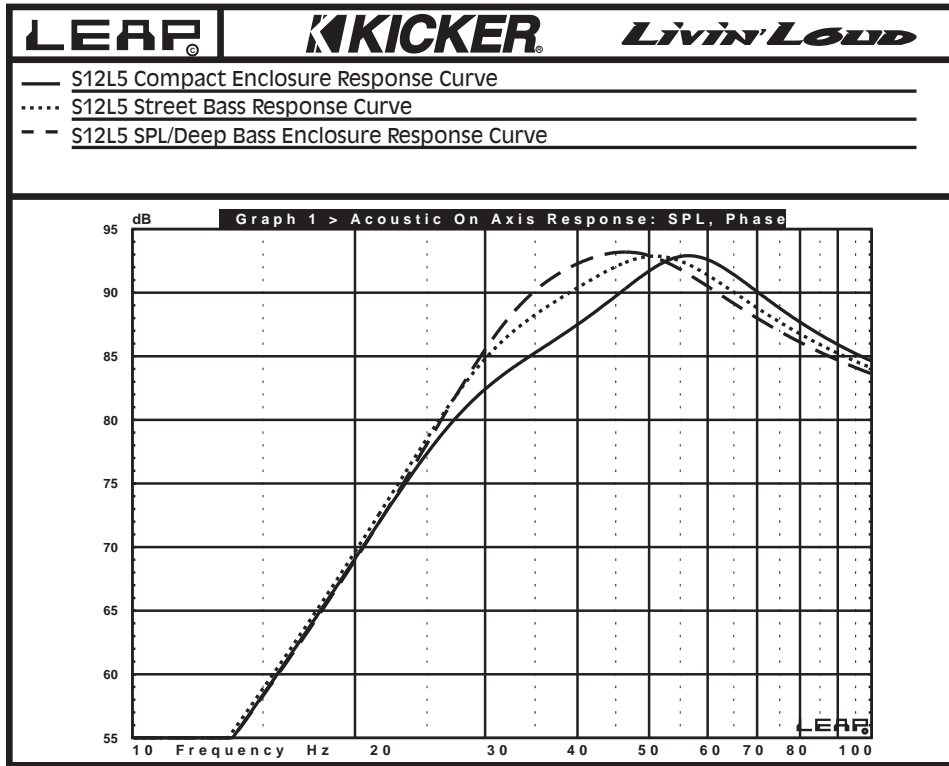

S15L5 3.0cu.ft./4.5cu.ft./6.0cu.ft.

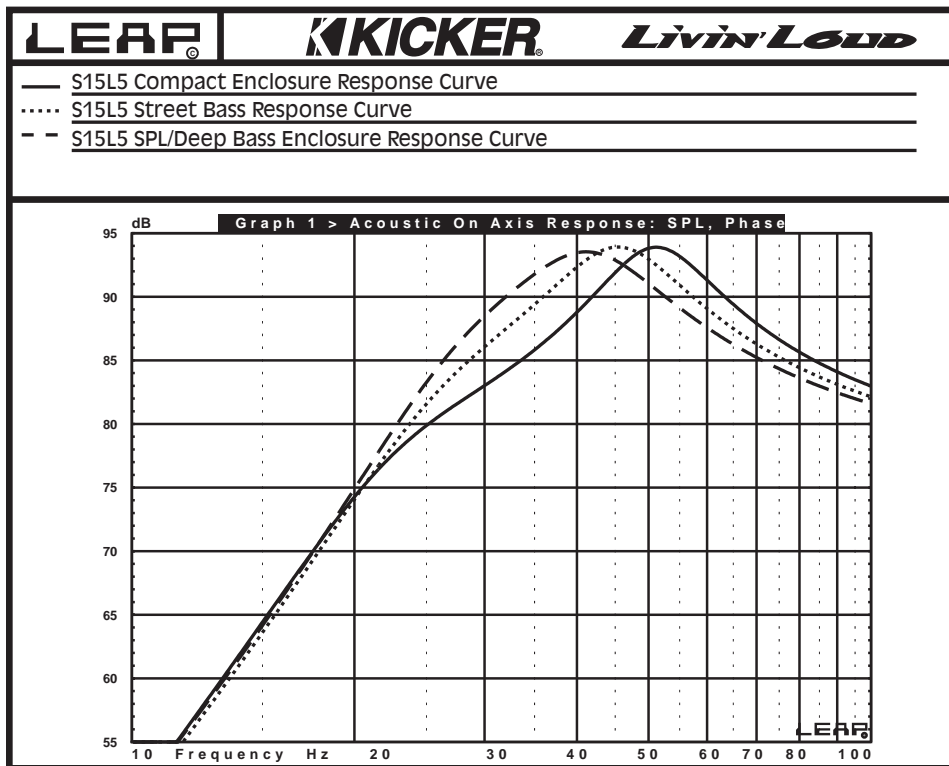

Box Building & Mounting Hints

All the cubic feet numbers given in the supplied charts include the displacement of the woofer. For the ported boxes the displacement of the port must be added to the final design. It will be impractical to use round ports for these designs. The rectangular port information given will yield the best results.

Always use 3/4" or thicker MDF and make sure all the joints are secure and well sealed. The peak pressure in a ported box can exceed that of a sealed enclosure. All of these designs need some internal bracing. Be sure to add 2"x2" to 3"x3" triangle braces between each of the larger unsupported panels. Kicker recommends using a good grade of wood glue and silicone sealer for an airtight box.

Note: If you prefer an ultra-smooth bass response, you should loosely fill your ported Solo-Baric Enclosure with polyfil. If you do so, the entrance to the port (inside the box) must be covered with hardware cloth, chicken wire, or expanded metal to prevent the polyfil from being blown out through the port. Use of polyfil will slightly decrease efficiency, but will deepen and extend low bass response.

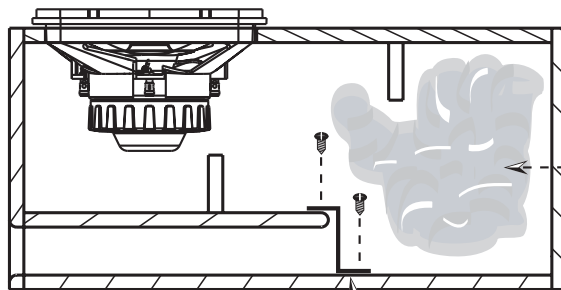
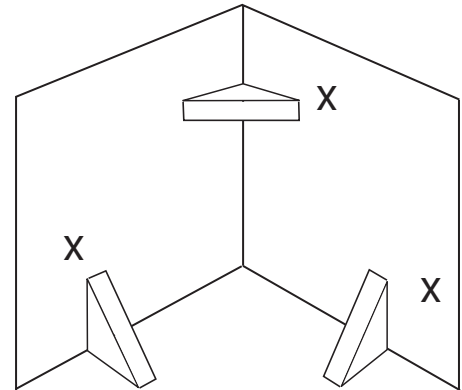

50 % filled with Polyfil

Chicken Wire or Expanded Metal

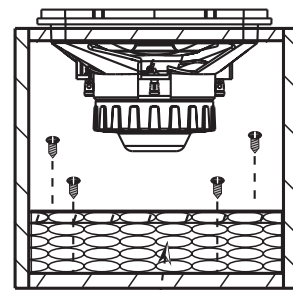

Chicken Wire or Expanded Metal

Do not install a ported box with the port against a solid surface. The port opening must remain unobstructed. Use the smallest dimension of the rectangular port as the minimum amount of space required between the port and any surface to insure unrestricted airflow.

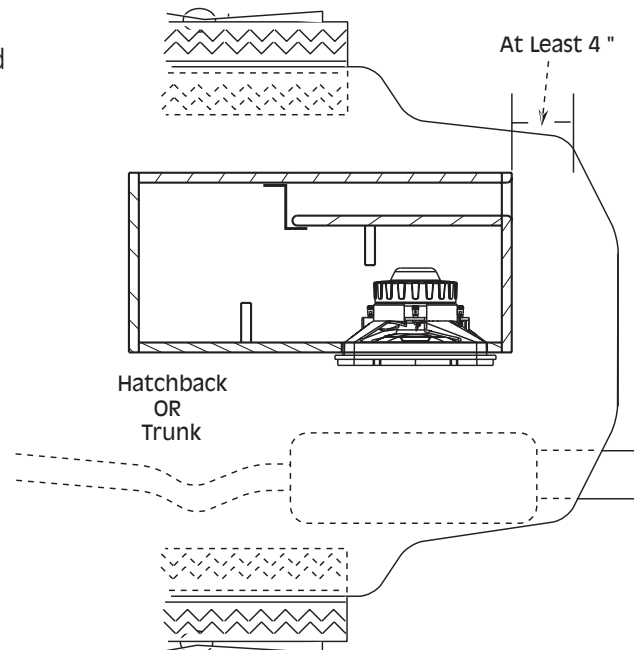

At Least 4"

Hatchback OR Trunk

Box Building & Mounting Hints

If you would like to use a vented enclosure, but the box designs we provide you with (in this manual) do not fit because of width or depth the designs can be modified. The shape of the enclosure is not vital, but **The Volume Is**. The volume, of the design you choose, must stay the same. The following diagrams provide you with some help to insure your enclosure is built correctly.

Front

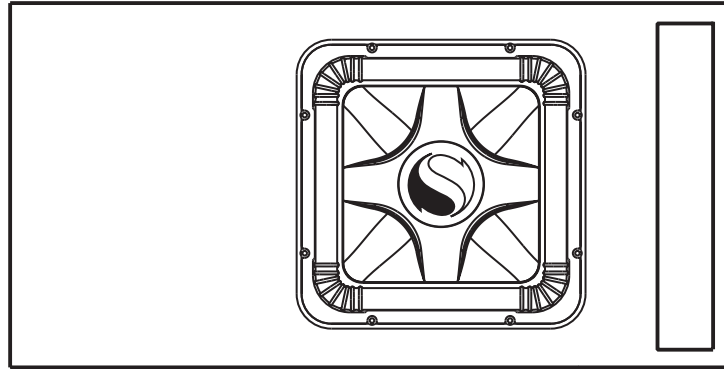

Top

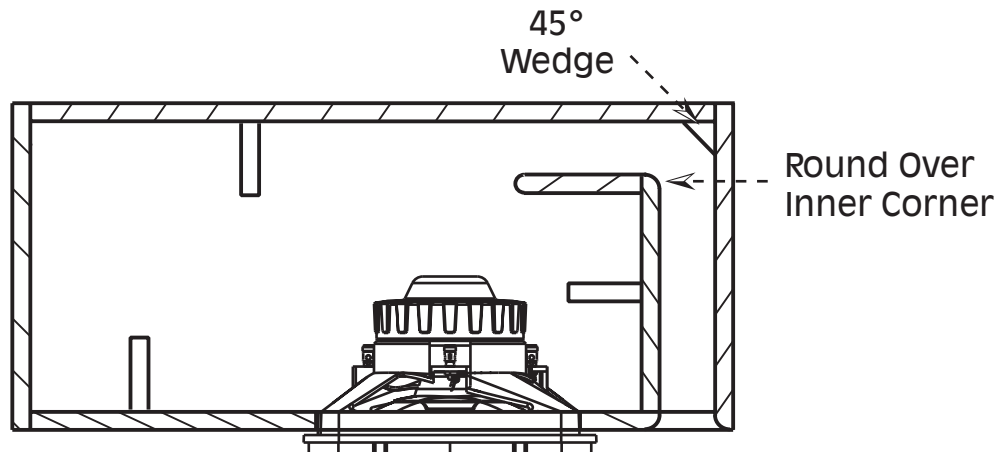

Remember:

If you are going to bend the port at 90° you will need to add 1/2 of the ports height to the length! See Below.

Example:

(Fig. 1)

$H_{port} = 3"$

$W_{port} = 10"$

$L_{port} = 20"$

(Fig. 2)

Since H_{port} is 3" you need to add 1.5" (1/2 of H_{port}) to L_{port} . This means that $L^1 + L^2 = 21.5"$

Always measure L^1 and L^2 down the center to get an accurate measurement!

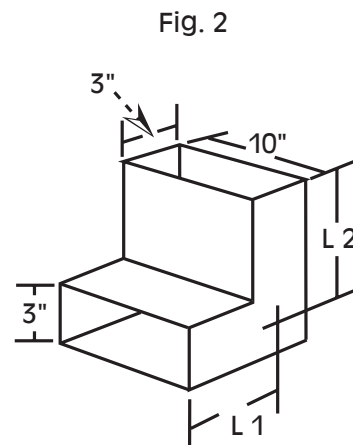
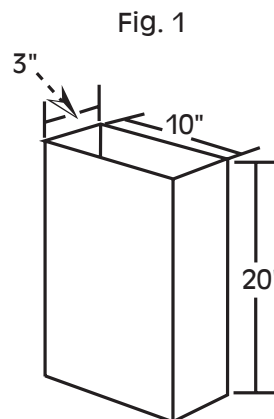

Box Building & Mounting Hints

Here are a couple more examples of the different shape enclosures you can build. The woofer can be mounted on the same side as the port or the back side of the enclosure can be slanted to fit up against your back seat.. On the cut sheets we provide, change the dimensions to accommodate the woofer and the vent on the same side. Make sure the internal volume does not change!

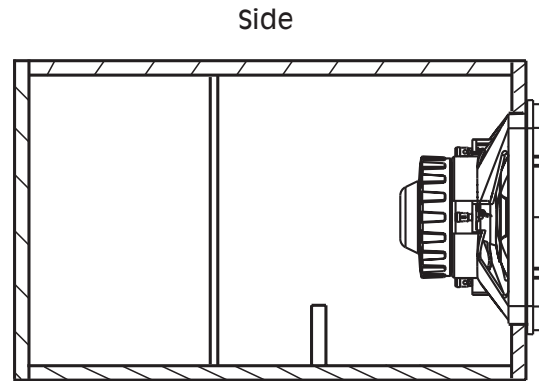
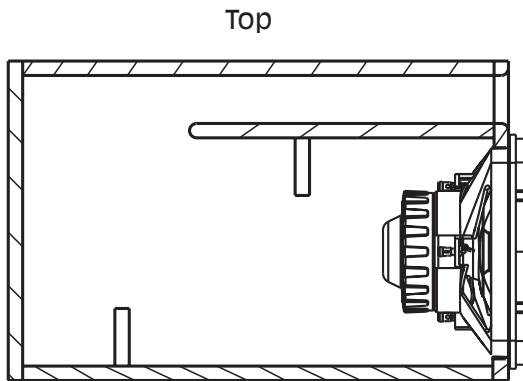

OR

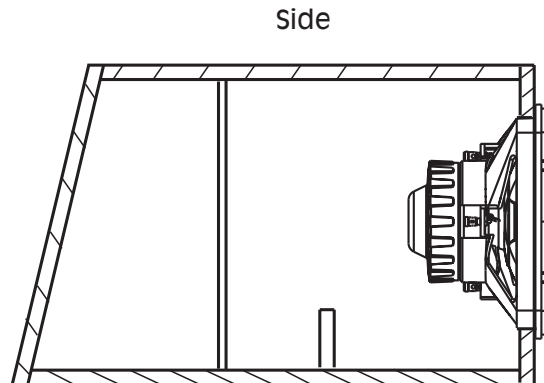
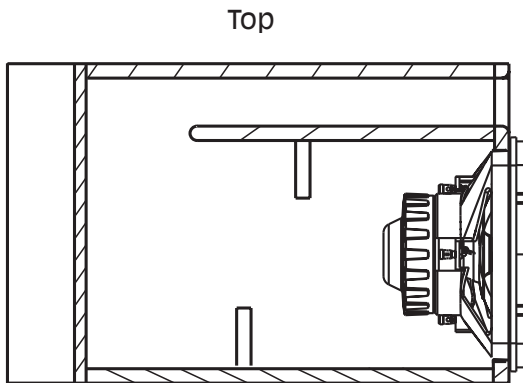

Wiring Options

The following diagrams are the most popular wiring configurations when using Dual voice coil woofers. They show a typical single channel wiring scheme. Check the amplifier's owners manual for minimum impedance the amplifier will handle before hooking up the speakers. Remember: 4 Ohm mono is equivalent to 2 Ohm stereo.

Single Woofer Using Dual 2 Ohm Voice Coils

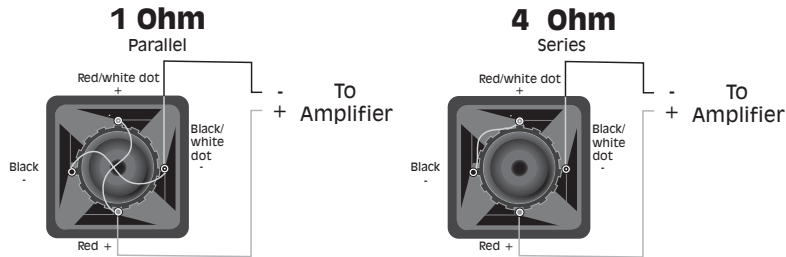

Using Dual 4 Ohm Voice Coils

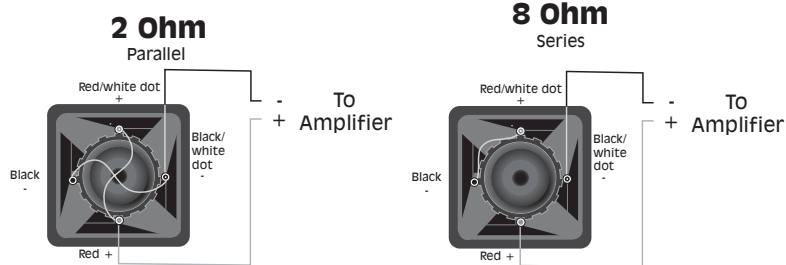

SERIES VOICE COILS / WOOFERS WIRED IN PARALLEL

PARALLELED VOICE COILS / WOOFERS WIRED IN SERIES

Using Dual 2 Ohm Voice Coils

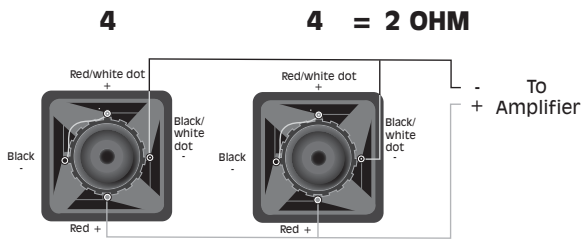

Using Dual 2 Ohm Voice Coils

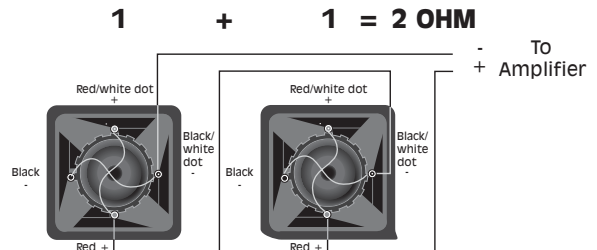

Using Dual 4 Ohm Voice Coils

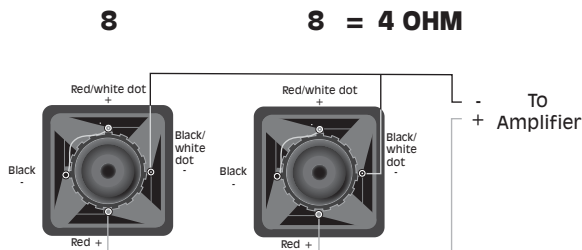

Using Dual 4 Ohm Voice Coils

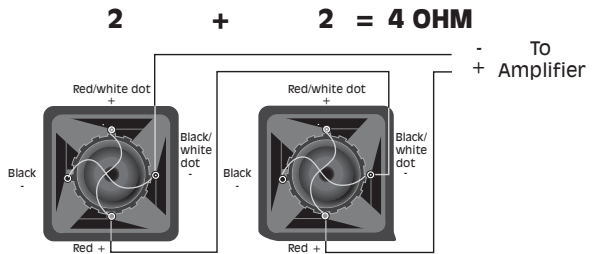

Wiring Options cont.

SERIES VOICE COILS / WOOFERS WIRED IN PARALLEL

Using Dual 2 Ohm Voice Coils

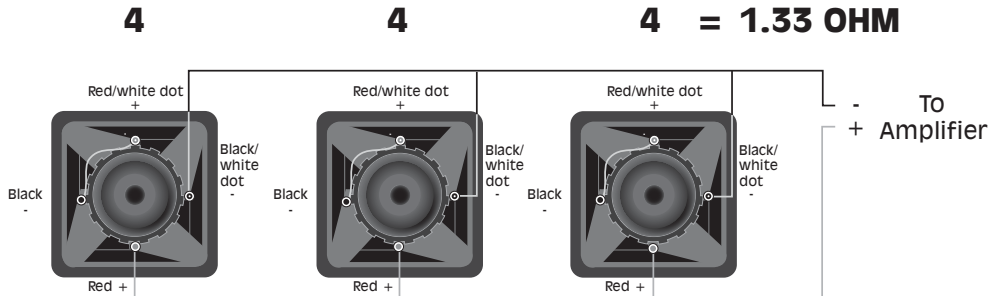

Using Dual 4 Ohm Voice Coils

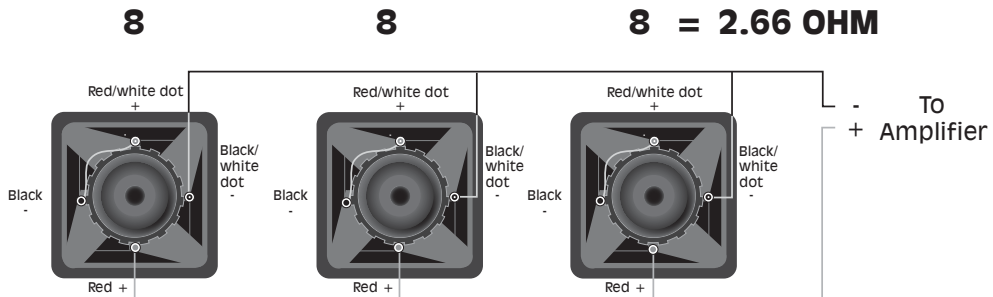

SERIES VOICE COILS / WOOFERS WIRED IN PARALLEL

Using Dual 2 Ohm Voice Coils

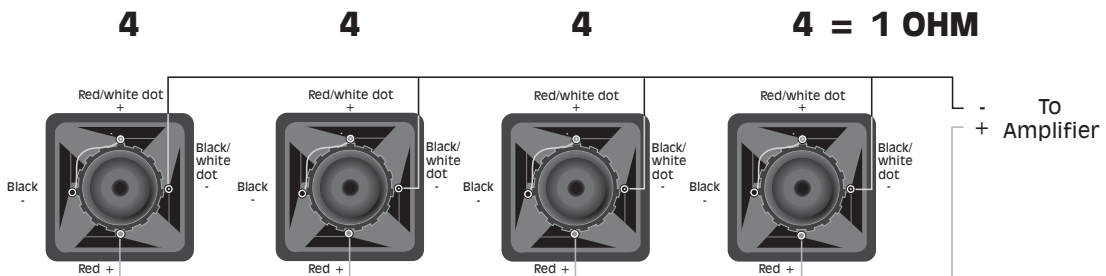

Using Dual 4 Ohm Voice Coils

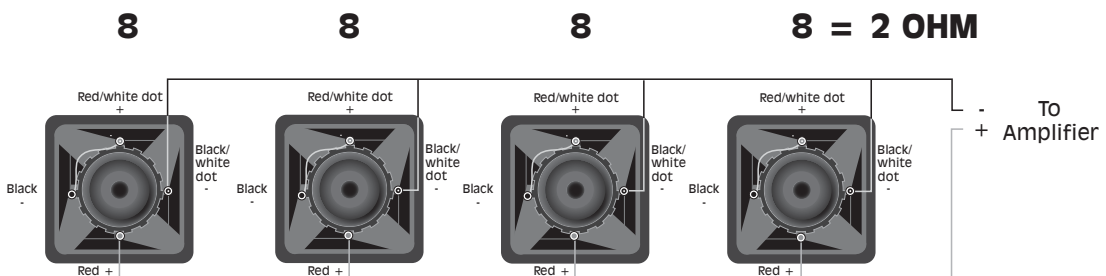



.66 cf, Fb = 48Hz
 .16 cf = Port Vol.

S8L5-BOX-VENTED-066

POWER HANDLING:
 300W with 25Hz Subsonic Filter
 set at 24db/Octave.
 Without subsonic filter 210W

Side View

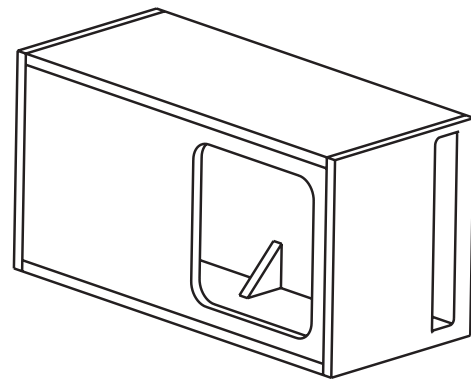
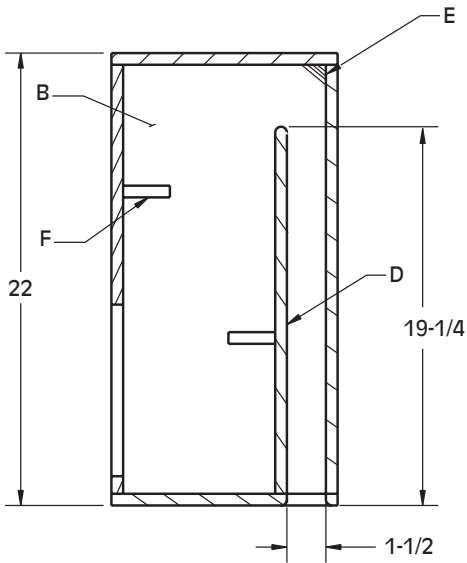

Front View

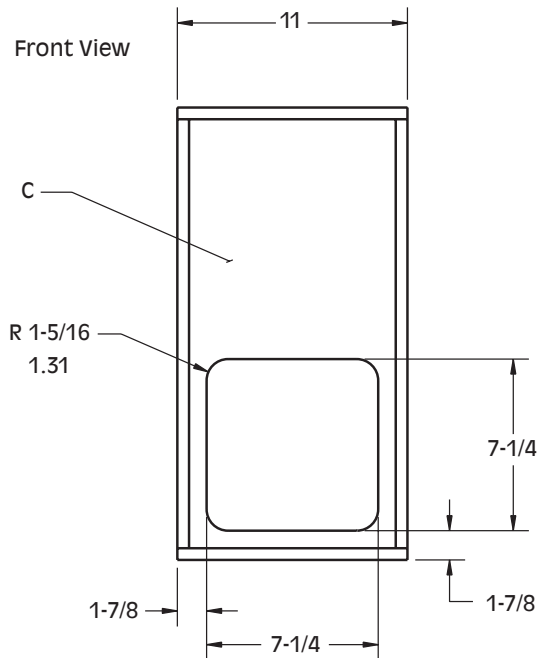

Cut List: 3/4" MDF

- (2) 11" x 9 5/8" Top & Bottom(A)
- (2) 20 1/2" x 9 5/8" Sides(B)
- (2) 20-1/2" x 9 1/2" Front & Back(C)
- (1) 18 1/2" x 9 1/2" Port(D)
- (1) 1 1/2" x 9 1/2" Corner Fillet(E)
- (4) 2" x 2" Gusset(F)

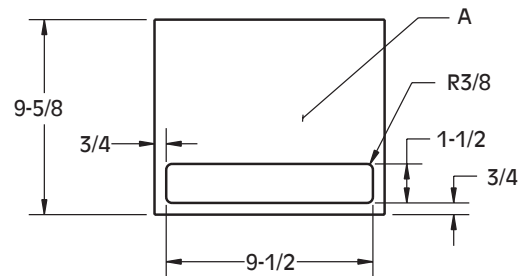



.80 cf, Fb = 45Hz
 .19 cf = Port Vol.

S8L5-BOX-VENTED-080

POWER HANDLING:
 300W with 25Hz Subsonic Filter
 set at 24db/Octave.
 Without subsonic filter 210W

Side View

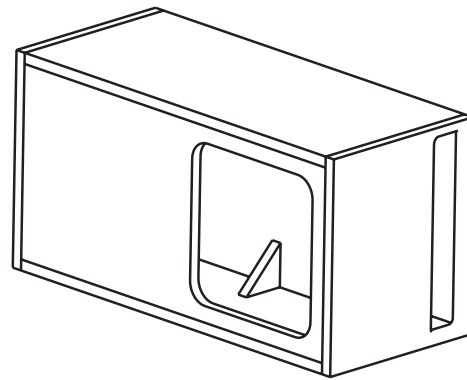
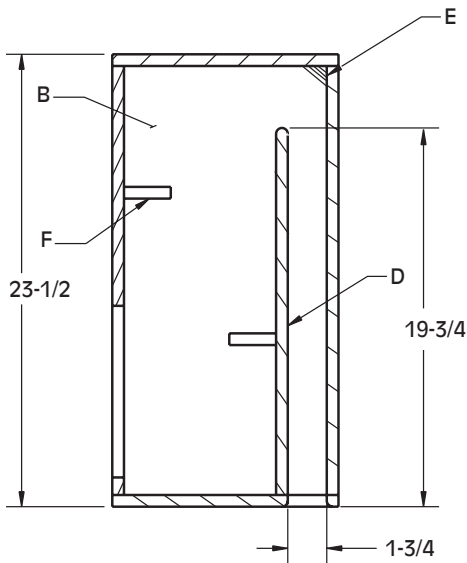

Front View

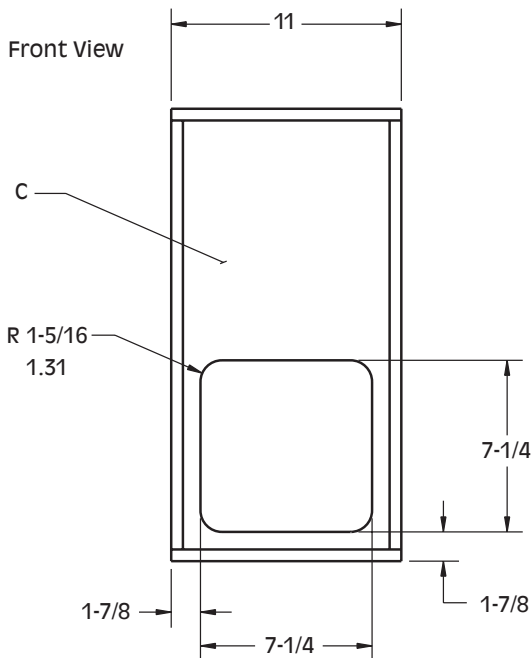

Cut List: 3/4" MDF

- (2) 11" x 10 5/8" Top & Bottom(A)
- (2) 22" x 10 5/8" Sides(B)
- (2) 22" x 9 1/2" Front & Back(C)
- (1) 19" x 9 1/2" Port(D)
- (1) 1 1/2" x 9 1/2" Corner Fillet(E)
- (4) 2" x 2" Gusset(F)

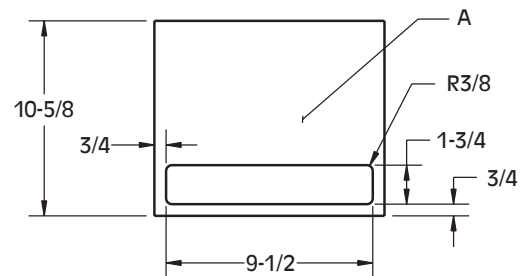



1.0 cf, Fb = 42Hz
 .23 cf = Port Vol.

S8L5-BOX-VENTED-10

POWER HANDLING:
 300W with 25Hz Subsonic Filter
 set at 24db/Octave.
 Without subsonic filter 210W

Side View

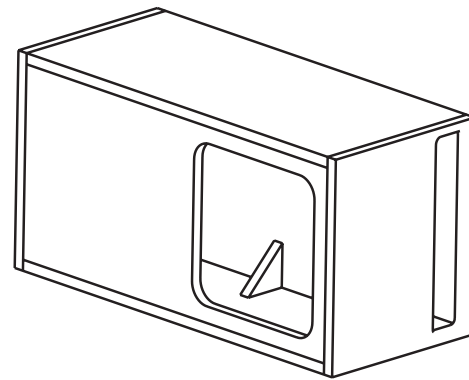
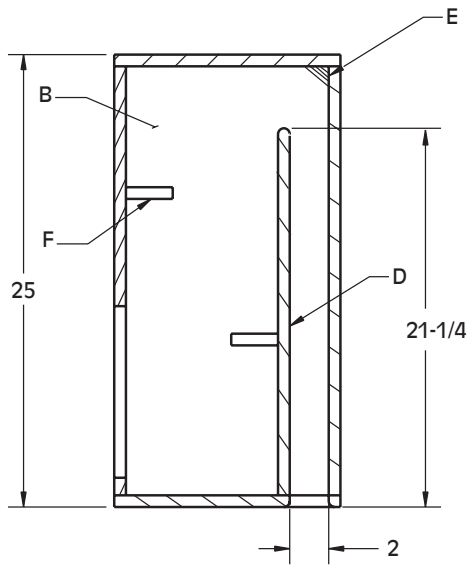

Front View

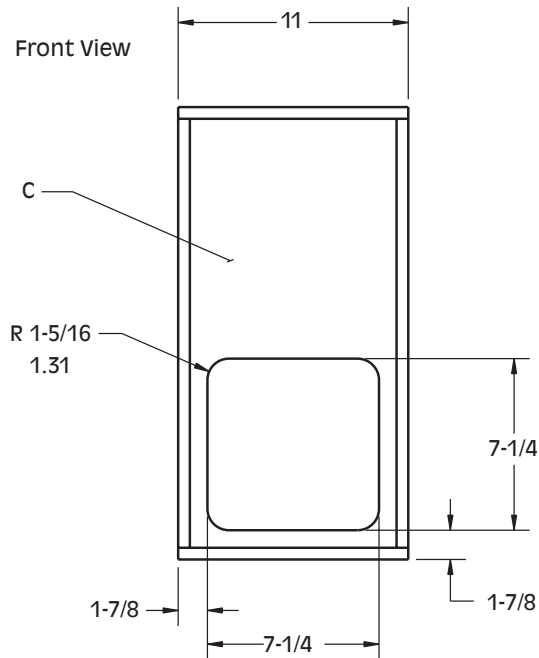

Cut List: 3/4" MDF

- (2) 11" x 12" Top & Bottom(A)
- (2) 23 1/2" x 12" Sides(B)
- (2) 23 1/2" x 9 1/2" Front & Back(C)
- (1) 20 1/2" x 9 1/2" Port(D)
- (1) 1 1/2" x 9 1/2" Corner Fillet(E)
- (4) 2" x 2" Gusset(F)

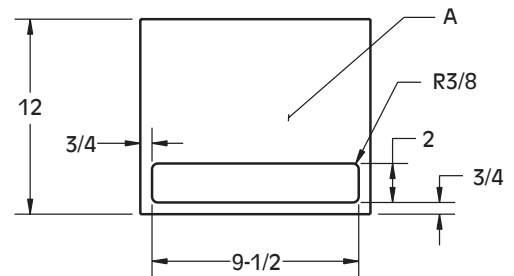



1.25 cf, Fb = 45Hz
 .32 cf = Port Vol.

S10L5-BOX-VENTED-125

POWER HANDLING:
 425W with 25Hz Subsonic Filter
 set at 24db/Octave.
 Without subsonic filter 298W

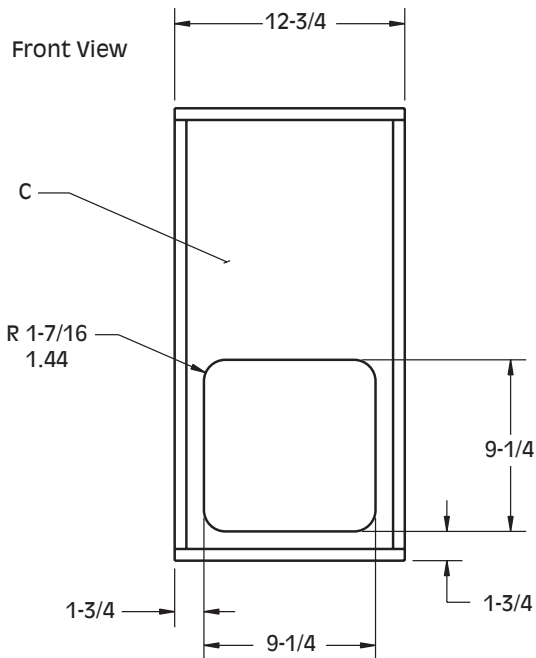
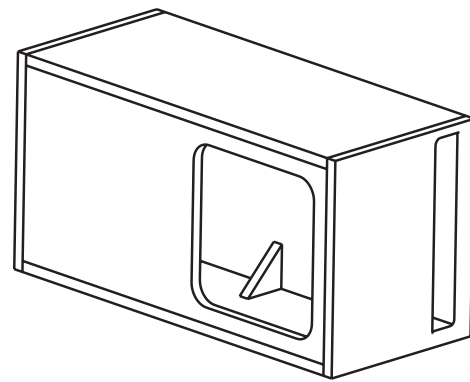
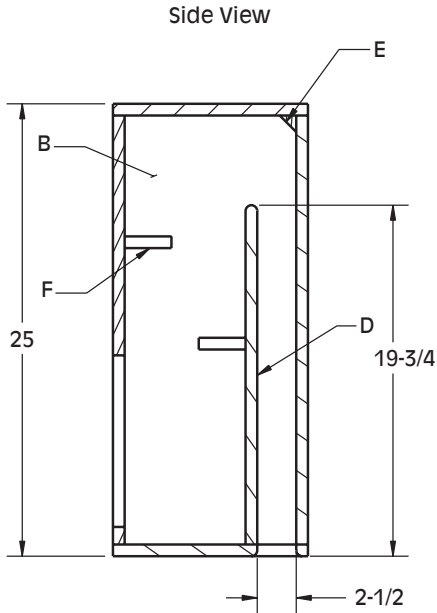

Cut List: 3/4" MDF

- (2) 12 3/4" x 13" Top & Bottom(A)
- (2) 23 1/2" x 13" Sides(B)
- (2) 23 1/2" x 11 1/4" Front & Back(C)
- (1) 19" x 11 1/4" Port(D)
- (1) 1 1/2" x 11 1/4" Corner Fillet(E)
- (4) 2" x 2" Gusset(F)

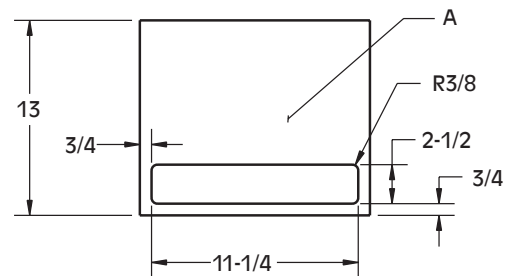



1.75 cf, Fb = 42Hz
 .32 cf = Port Vol.

S10L5-BOX-VENTED-175

POWER HANDLING:
 450W with 25Hz Subsonic Filter
 set at 24db/Octave.
 Without subsonic filter 315W

Side View

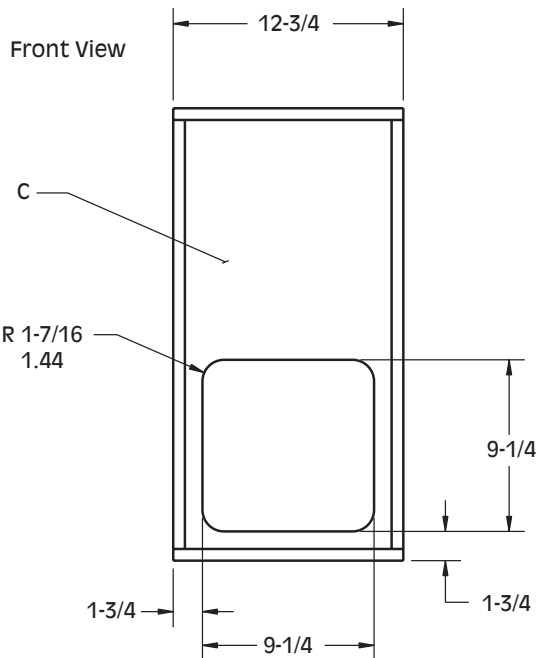
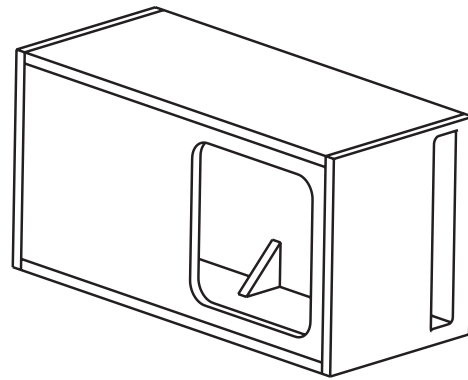
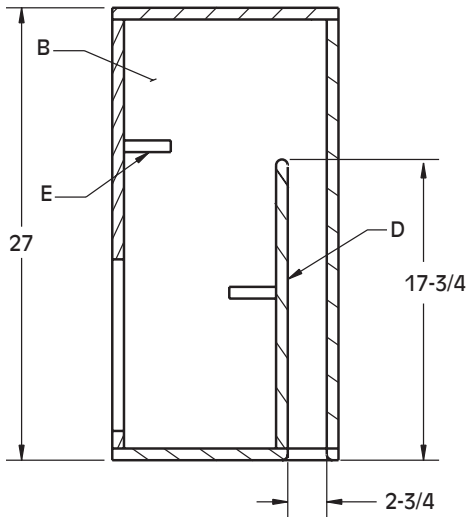

Cut List: 3/4" MDF

- (2) 12 3/4" x 15" Top & Bottom(A)
- (2) 25 1/2" x 15" Sides(B)
- (2) 25 1/2" x 11 1/4" Front & Back(C)
- (1) 17" x 11 1/4" Port(D)
- (4) 2" x 2" Gusset(E)

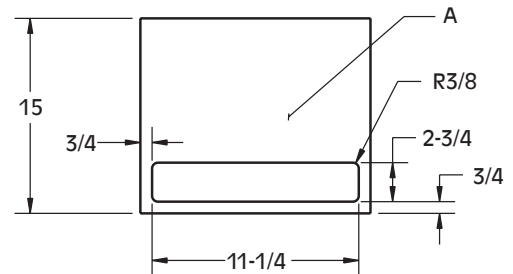



2.25 cf, Fb = 38Hz
 .35 cf = Port Vol.

S10L5-BOX-VENTED-225

POWER HANDLING:
 450W with 25Hz Subsonic Filter
 set at 24db/Octave.
 Without subsonic filter 315W

Side View

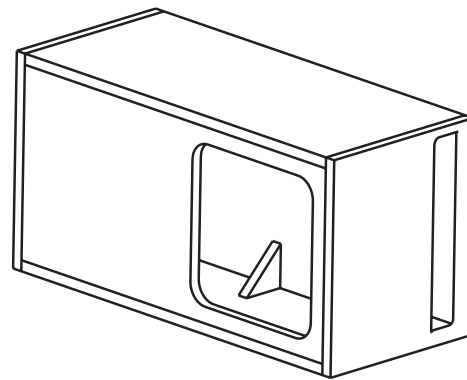
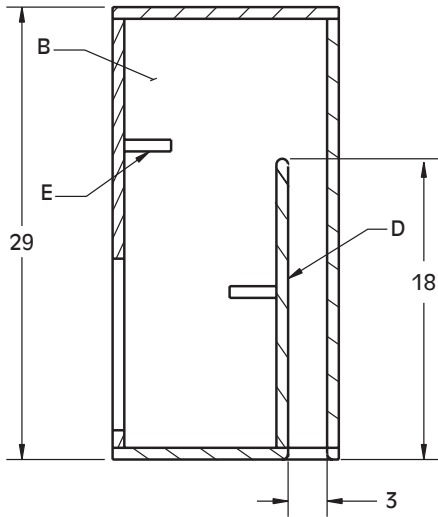

Front View

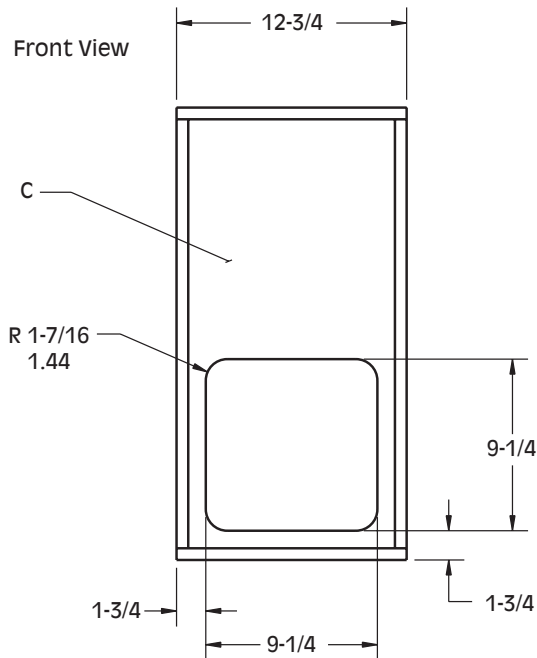

Cut List: 3/4" MDF

- (2) 12 3/4" x 16 1/2" Top & Bottom(A)
- (2) 27 1/2" x 16 1/2" Sides(B)
- (2) 27 1/2" x 11 1/4" Front & Back(C)
- (1) 17 1/4" x 11 1/4" Port(D)
- (4) 2" x 2" Gusset(E)

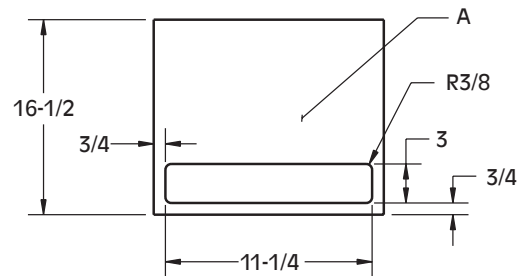



1.75 cf, Fb = 40Hz
 .43 cf = Port Vol.

S12L5-BOX-VENTED-175

POWER HANDLING:

600W with 25Hz Subsonic Filter
 set at 24db/Octave.
 Without subsonic filter 420W

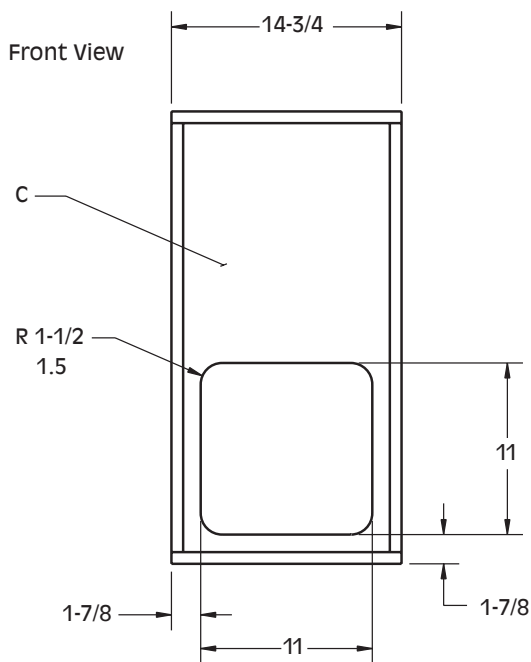
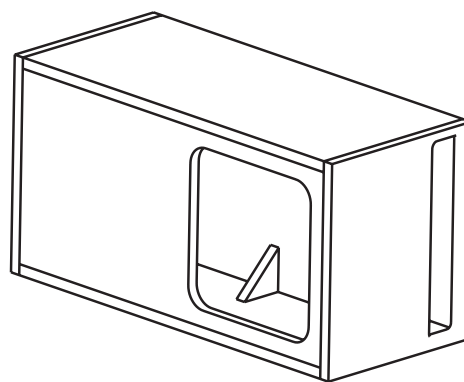
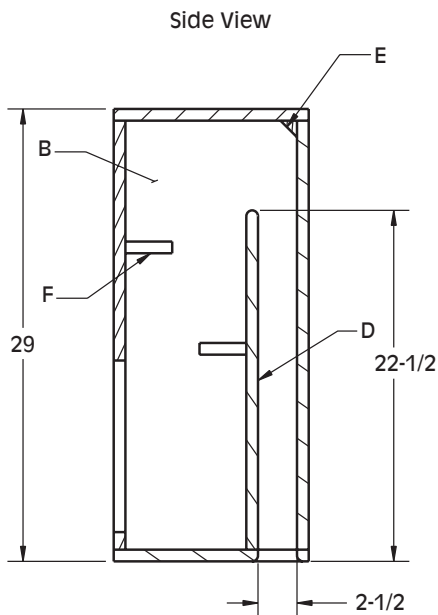

Cut List: 3/4" MDF

- (2) 14 3/4" x 12 1/2" Top & Bottom(A)
- (2) 27 1/2" x 12 1/2" Sides(B)
- (2) 27 1/2" x 13 1/4" Front & Back(C)
- (1) 21 3/4" x 13 1/4" Port(D)
- (1) 1 1/2" x 13 1/4" Corner Fillet(E)
- (4) 3" x 3" Gusset(F)

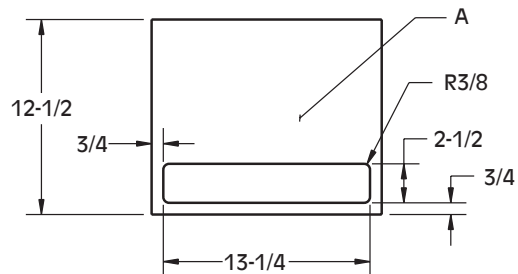



2.50 cf, Fb = 38Hz
 .32 cf = Port Vol.

S12L5-BOX-VENTED-250

POWER HANDLING:
 550W with 25Hz Subsonic Filter
 set at 24db/Octave.
 Without subsonic filter 340W

Side View

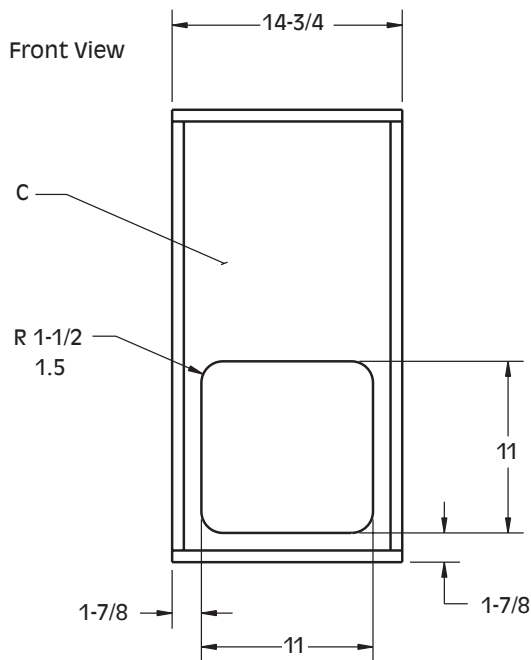
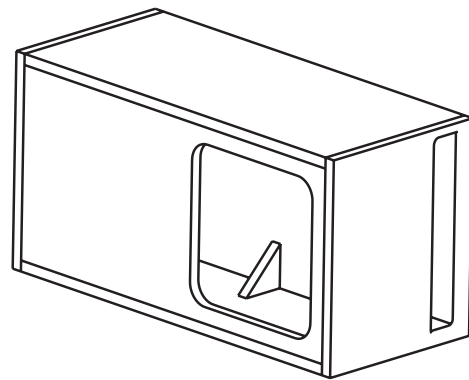
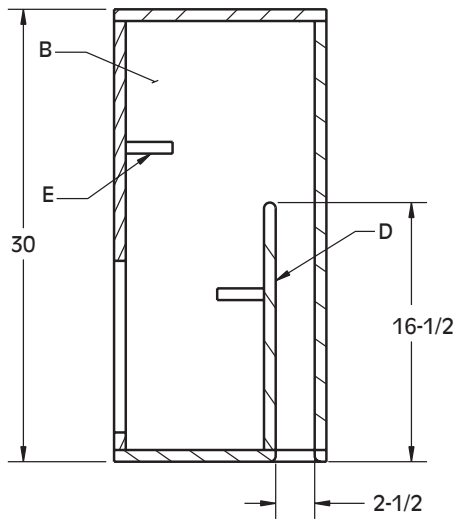

Cut List: 3/4" MDF

- (2) 14 3/4" x 14 3/4" Top & Bottom(A)
- (2) 28 1/2" x 14 3/4" Sides(B)
- (2) 28 1/2" x 13 1/4" Front & Back(C)
- (1) 15 3/4" x 13 1/4" Port(D)
- (4) 3" x 3" Gusset(E)

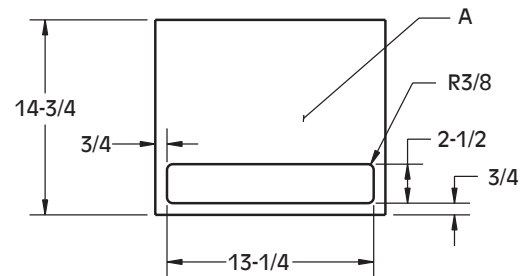



3.25 cf, Fb = 37Hz
 .33 cf = Port Vol.

S12L5-BOX-VENTED-325

POWER HANDLING:
 600W with 25Hz Subsonic Filter
 set at 24db/Octave.
 Without subsonic filter 420W

Side View

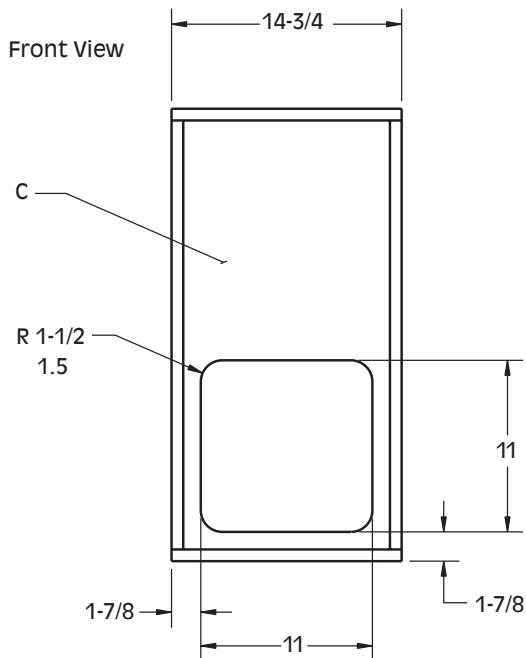
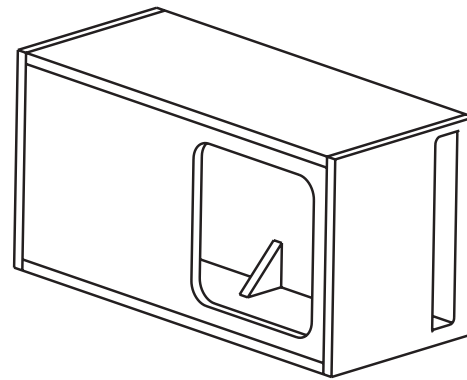
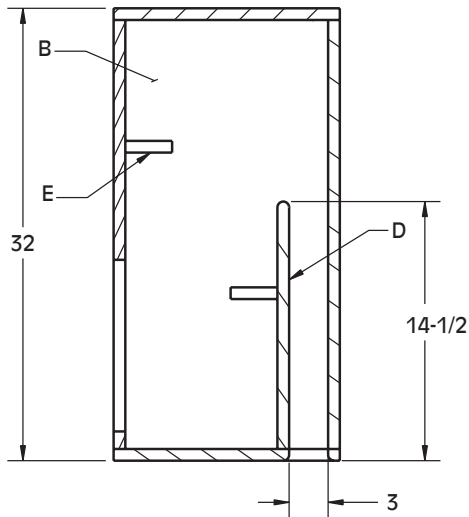

Cut List: 3/4" MDF

- (2) 14 3/4" x 17-1/8" Top & Bottom(A)
- (2) 30 1/2" x 17-1/8" Sides(B)
- (2) 30-1/2" x 13 1/4" Front & Back(C)
- (1) 13 3/4" x 13 1/4" Port(D)
- (4) 3" x 3" Gusset(E)

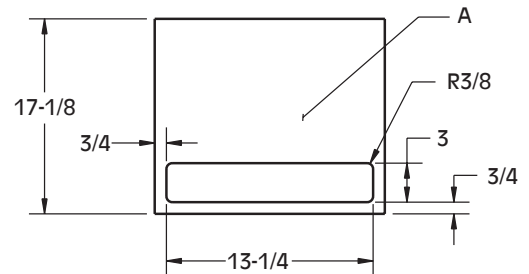



3.00 cf, Fb = 35Hz
 .46 cf = Port Vol.

S15L5-BOX-VENTED-300

POWER HANDLING:
 750W with 25Hz Subsonic Filter
 set at 24db/Octave.
 Without subsonic filter 525W

Side View

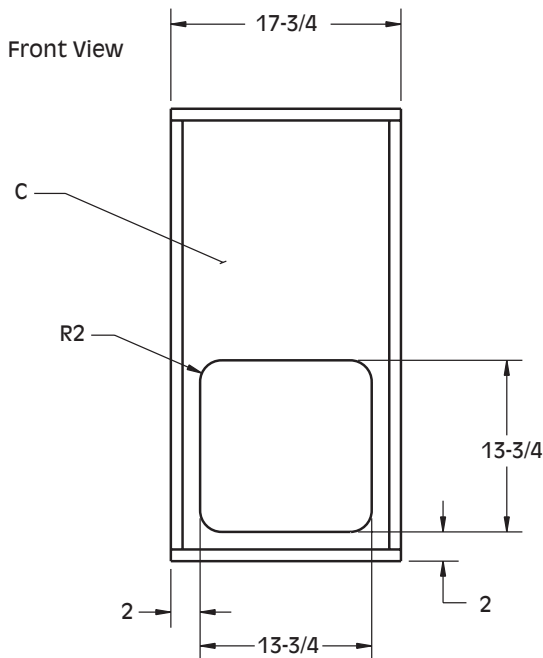
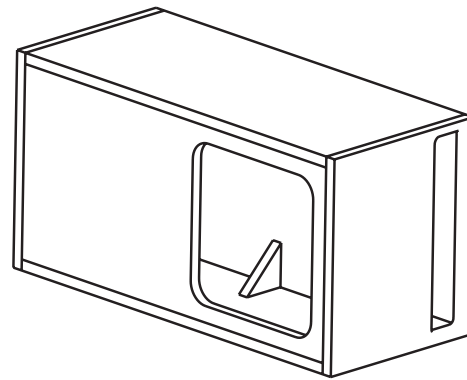
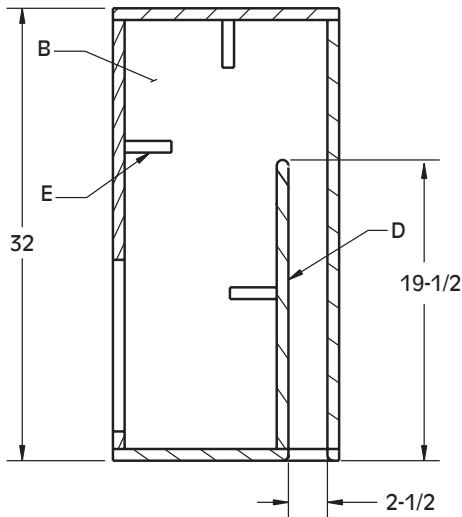

Cut List: 3/4" MDF

- (2) 17 3/4" x 14 1/4" Top & Bottom(A)
- (2) 30 1/2" x 14 1/4" Sides(B)
- (2) 30 1/2" x 16 1/4" Front & Back(C)
- (1) 18 3/4" x 16 1/4" Port(D)
- (4) 3" x 3" Gusset(E)

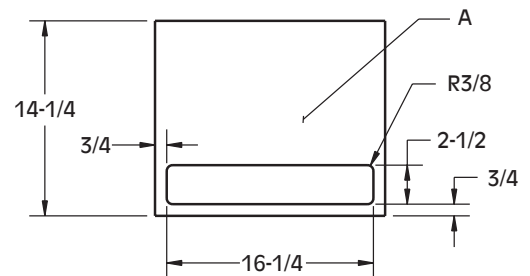



4.50 cf, Fb = 33Hz
 .42 cf = Port Vol.

S15L5-BOX-VENTED-450

POWER HANDLING:
 750W with 25Hz Subsonic Filter
 set at 24db/Octave.
 Without subsonic filter 525W

Side View

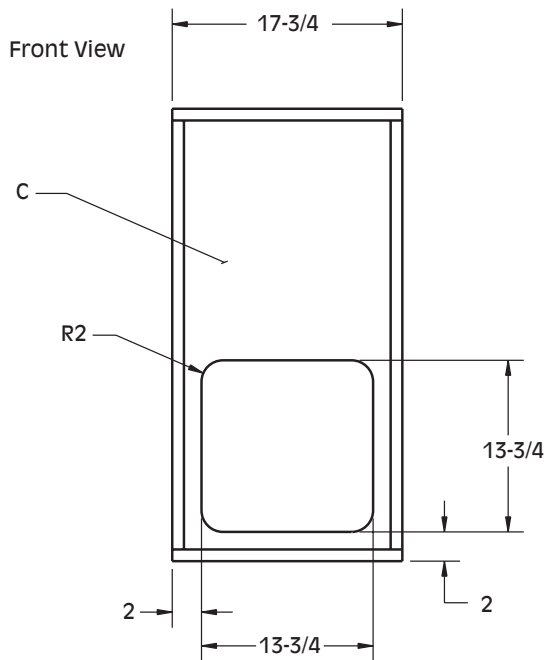
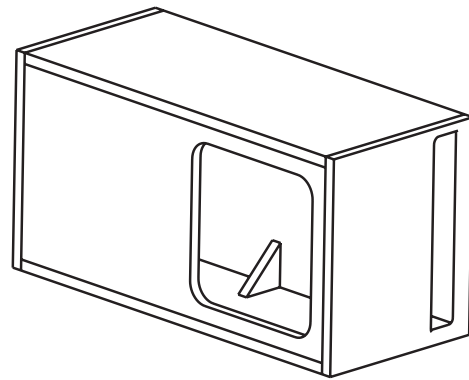
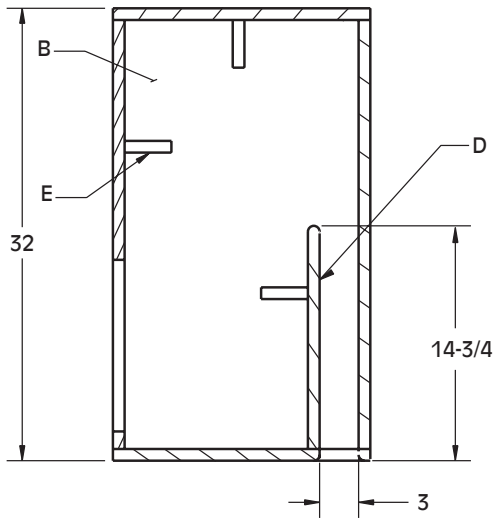

- Cut List: 3/4" MDF
- (2) 17 3/4" x 19" Top & Bottom(A)
 - (2) 30 1/2" x 19" Sides(B)
 - (2) 30 1/2" x 16 1/4" Front & Back(C)
 - (1) 14" x 16 1/4" Port(D)
 - (6) 3" x 3" Gusset(E)

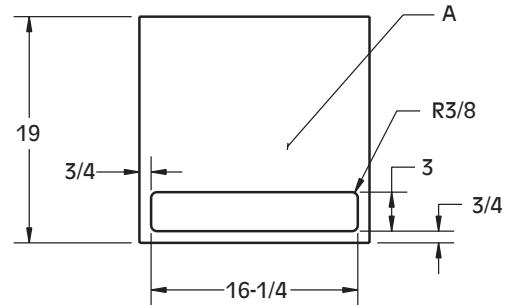



6.00 cf, Fb = 30Hz
 .45cf = Port Vol.

S15L5-BOX-VENTED-600

Side View

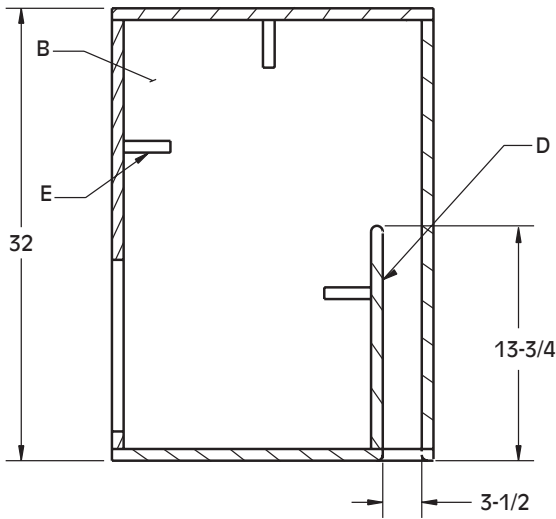

POWER HANDLING:
 750W with 25Hz Subsonic Filter
 set at 24db/Octave.
 Without subsonic filter 525W

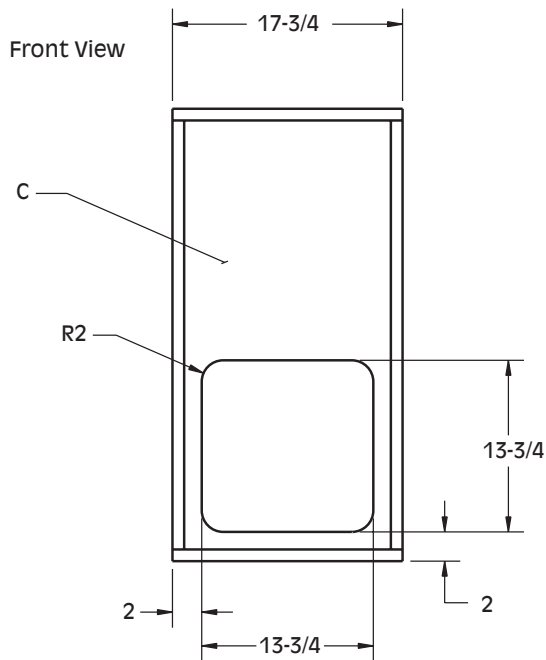
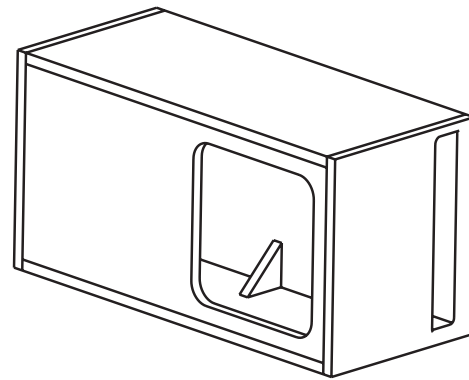

- Cut List: 3/4" MDF
- (2) 17 3/4" x 24 1/4" Top & Bottom(A)
 - (2) 30 1/2" x 24 1/4" Sides(B)
 - (2) 30 1/2" x 16 1/4" Front & Back(C)
 - (1) 13" x 16 1/4" Port(D)
 - (6) 3" x 3" Gusset(E)

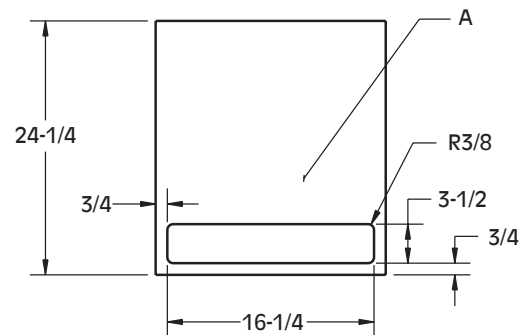

Resistance Formulas

Series Resistance

$$R_t = R_1 + R_2 + \dots$$

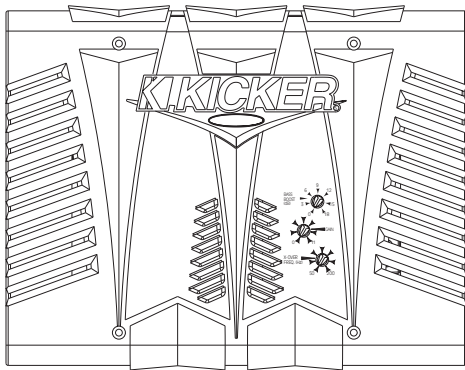

$$R_t = 4 \Omega + 4 \Omega = 8 \Omega$$

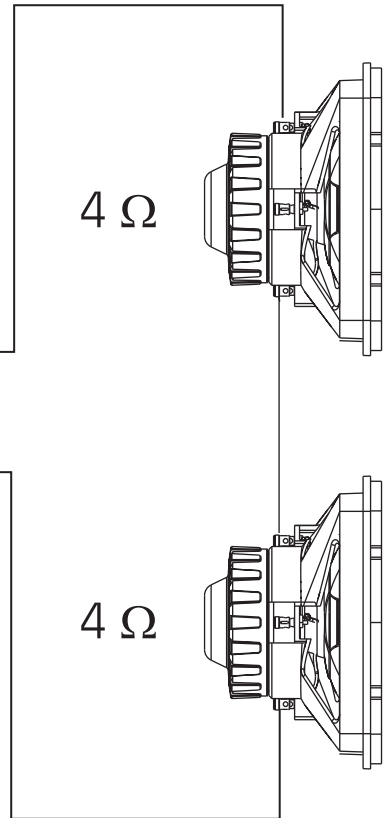

Parallel Resistance

$$R_t = (R_1 \times R_2) / (R_1 + R_2)$$

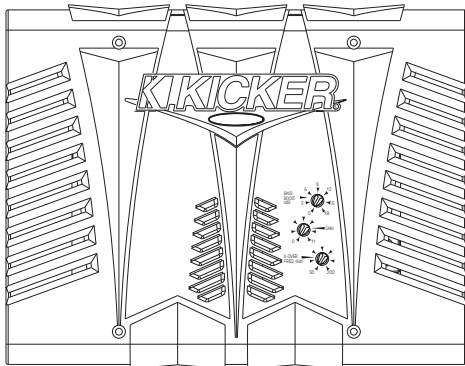

$$R_t = (4 \times 4) / (4 + 4)$$
$$R_t = (16) / (8) = 2 \Omega$$

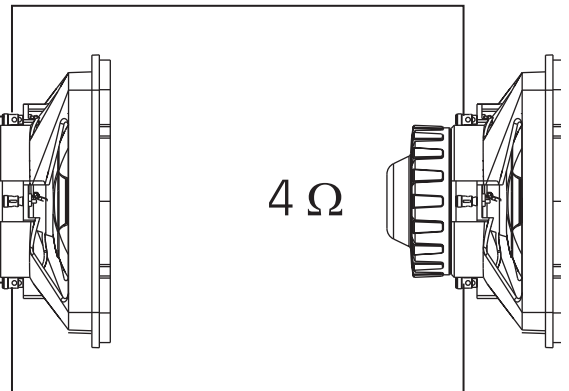

Thiele/Small Parameters

Model	S15L54	S12L54	S10L54	S8L54
Nominal Impedance (Coils in series)	8	8	8	8
SPL 1W/1M	87.6	87.3	86.0	83.8
Displacement, cc	3700	2150	1570	805
Displacement, Culn	225.7	131.1	95.6	49.1
Mounting Depth	7-7/8	6-3/8	5-11/16	4-7/8
Revc	7.74	6.88	6.94	6.67
VC Inductance, mH	7.57	5.74	5.88	4.60
Sd, SqM	0.1056	0.0645	0.0439	0.0273
BL	24.710	20.193	19.998	16.201
Vas, Liters	227.270	73.535	37.082	15.904
Vas, CuFt	8.03	2.60	1.31	0.56
Mms, gms	354.0	207.8	163.5	111.5
Fs	22.3	31.3	33.8	38.9
Qms	11.396	10.495	10.552	8.873
Qes	0.630	0.689	0.603	0.692
Qts	0.597	0.647	0.570	0.642
Pmax, watts	750	600	450	300
Xmax, mm	15.50	12.45	12.45	9.65

Model	S15L52	S12L52	S10L52	S8L52
Nominal Impedance (Coils in series)	4	4	4	4
SPL 1W/1M	87.5	86.9	85.6	83.2
Displacement, cc	3700	2150	1570	805
Displacement, Culn	225.7	131.1	95.6	49.1
Mounting Depth	7-7/8	6-3/8	5-11/16	4-7/8
Revc	4.18	3.70	3.71	3.72
VC Inductance, mH	5.18	3.84	3.83	3.11
Sd, SqM	0.1056	0.0645	0.0439	0.0273
BL	19.645	15.692	16.292	12.537
Vas, Liters	206.801	76.077	32.050	17.329
Vas, CuFt	7.30	2.69	1.13	0.612
Mms, gms	373.9	222.7	184.5	117.0
Fs	22.8	29.7	34.2	36.4
Qms	11.988	11.405	10.122	9.829
Qes	0.580	0.625	0.555	0.633
Qts	0.553	0.592	0.526	0.594
Pmax, watts	750	600	450	300
Xmax, mm	15.50	12.45	12.45	9.65

Mounting Hole Cutouts

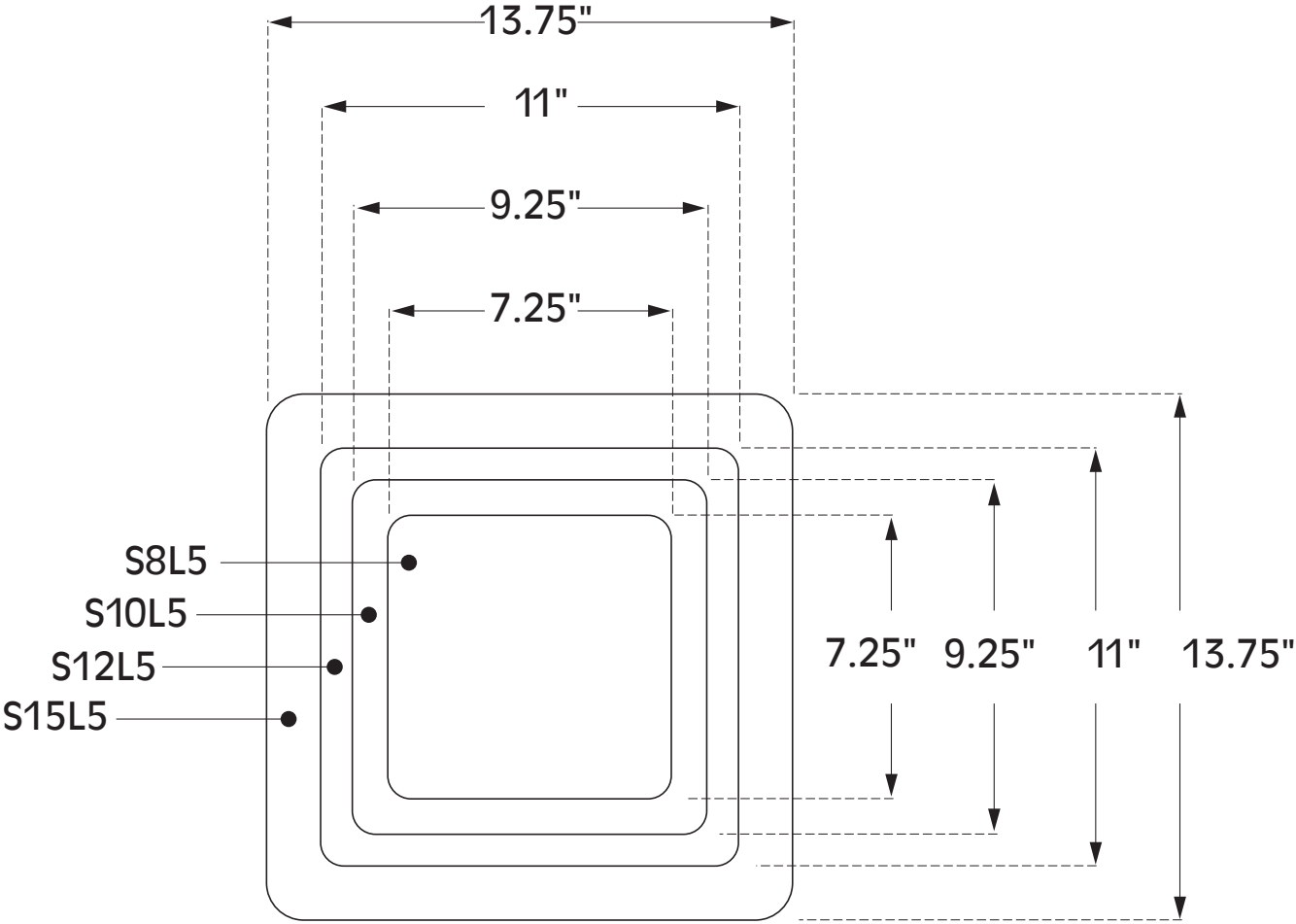

Notes

SPEAKER SYSTEMS LIMITED WARRANTY

Stillwater Designs warrants this product to be free from defects in material and workmanship under normal use for a period of **one (1) year from date of original purchase from an Authorized Kicker Dealer**, unless this product is labeled "B Stock", in which case it is warranted for ninety (90) days from date of purchase. Should service be necessary under this warranty for any reason due to manufacturing defect or malfunction during the warranty period, Stillwater Designs will replace or repair (at its discretion) the defective merchandise with equivalent merchandise at no charge. Warranty replacements on "B-Stock" may have cosmetic scratches and blemishes. Discontinued products may be replaced with equivalent products.

This warranty is valid only for the **original purchaser** and is not extended to owners of the product subsequent to the original purchaser. Any applicable implied warranties are limited in duration to a period of the express warranty as provided herein beginning with the date of the original purchase at retail, and no warranties, whether express or implied, shall apply to this product thereafter. Some states do not allow limitations on implied warranties, therefore these exclusions may not apply to you.

This warranty gives you specific legal rights; however you may have other rights that vary from state to state.

WHAT TO DO IF YOU NEED WARRANTY OR SERVICE

Defective merchandise must be returned to your local Authorized Stillwater Designs (Kicker) Dealer for warranty. Assistance in locating an Authorized Dealer can be obtained by writing or calling Stillwater Designs direct. You can confirm that a dealer is authorized by asking to see a current authorized dealer window decal.

If it becomes necessary for you to return defective merchandise, call the Kicker Customer Service Department at (405)624-8510 for a Return Authorization (RA) number. Package all defective items in the original container or in a package that will prevent shipping damage, and return to

Stillwater Designs, 5021 North Perkins Road, Stillwater, OK 74075

The RA number must be clearly marked on the outside of the package. Return only defective components. Return of entire cabinets, system packs, pairs, etc. increases your return freight charges. Non-defective items received will be returned freight collect.

Include a **dated proof-of-purchase** from an Authorized Dealer. Warranty expiration on items returned without proof-of-purchase will be determined from the manufacturing date code. Coverage may be invalidated if this date is greater than 18 months previous to the date item is sent in. Freight must be prepaid; items received freight collect will be refused.

Failure to follow these steps may void your warranty. Any questions can be directed to the Kicker Customer Service Department at (405)624-8510.

WHAT IS NOT COVERED?

This warranty is valid only if the product is used for the purpose for which it was designed. It does not cover:

- Install slips (screwdriver holes)
- Damage caused by exposure to water and/or excessive heat.
- Damage through negligence, misuse, or accident.
- Items physically damaged due to abuse.
- Freight damage.
- The cost of shipping product to Stillwater Designs Service.
- Items previously repaired by any unauthorized repair facility.
- Items returned from unauthorized individuals or dealers.
- Return shipping on non-defective items.
- Speakers damaged due to amplifier clipping or distortion.
- Speakers with silicon caulk used for gasket material.

HOW LONG WILL IT TAKE?

Stillwater Designs maintains a goal of 24-hour service for all returns. Delays may be incurred if lack of replacement inventory or parts is encountered.

INTERNATIONAL WARRANTY

Contact your International Stillwater Designs dealer or distributor concerning specific procedures for your country's warranty policies.



P.O. Box 459 • Stillwater, Oklahoma 74076 • U.S.A. • 405 624-8510

STILLWATER
Designs®

WARNING:

KICKER drivers are capable of producing sound levels that can permanently damage your hearing! Turning up a system to a level that has audible distortion is more damaging to your ears than listening to an undistorted system at the same volume level. The threshold of pain is always an indicator that the sound level is too loud and may permanently damage your hearing.

Please use common sense when controlling volume!

