

Title		
DARKB 4		
Size	Document Number	Rev
A3	INPUT & X-OVER 1/2	<RevCode>
Date:	Friday, May 11, 2007	Sheet 1 of 1

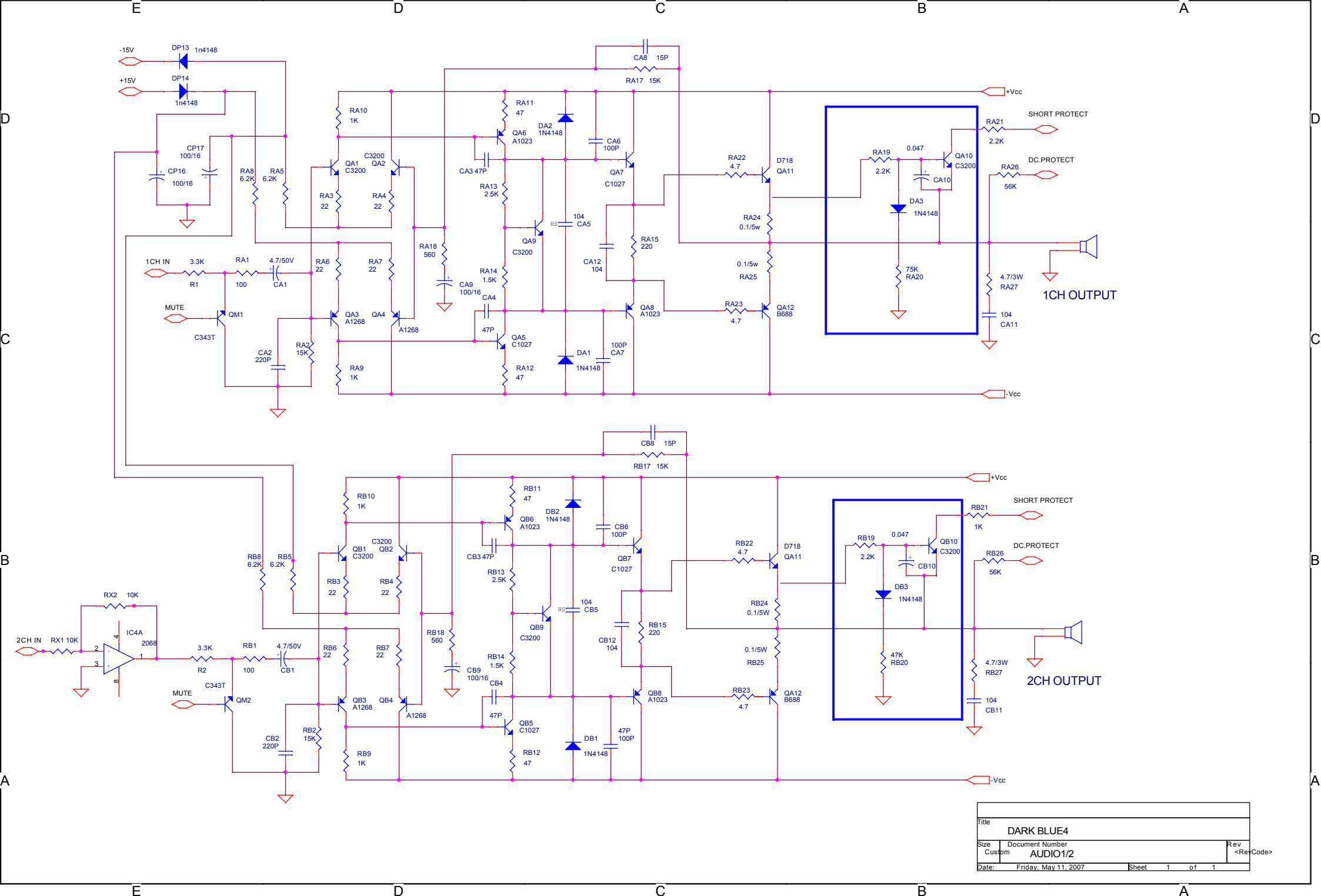

Title		DARK BLUE4	
Size	Document Number		
Custom	AUDIO1/2	Rev	<RevCode>
Date:	Friday, May 11, 2007	Sheet	1 of 1

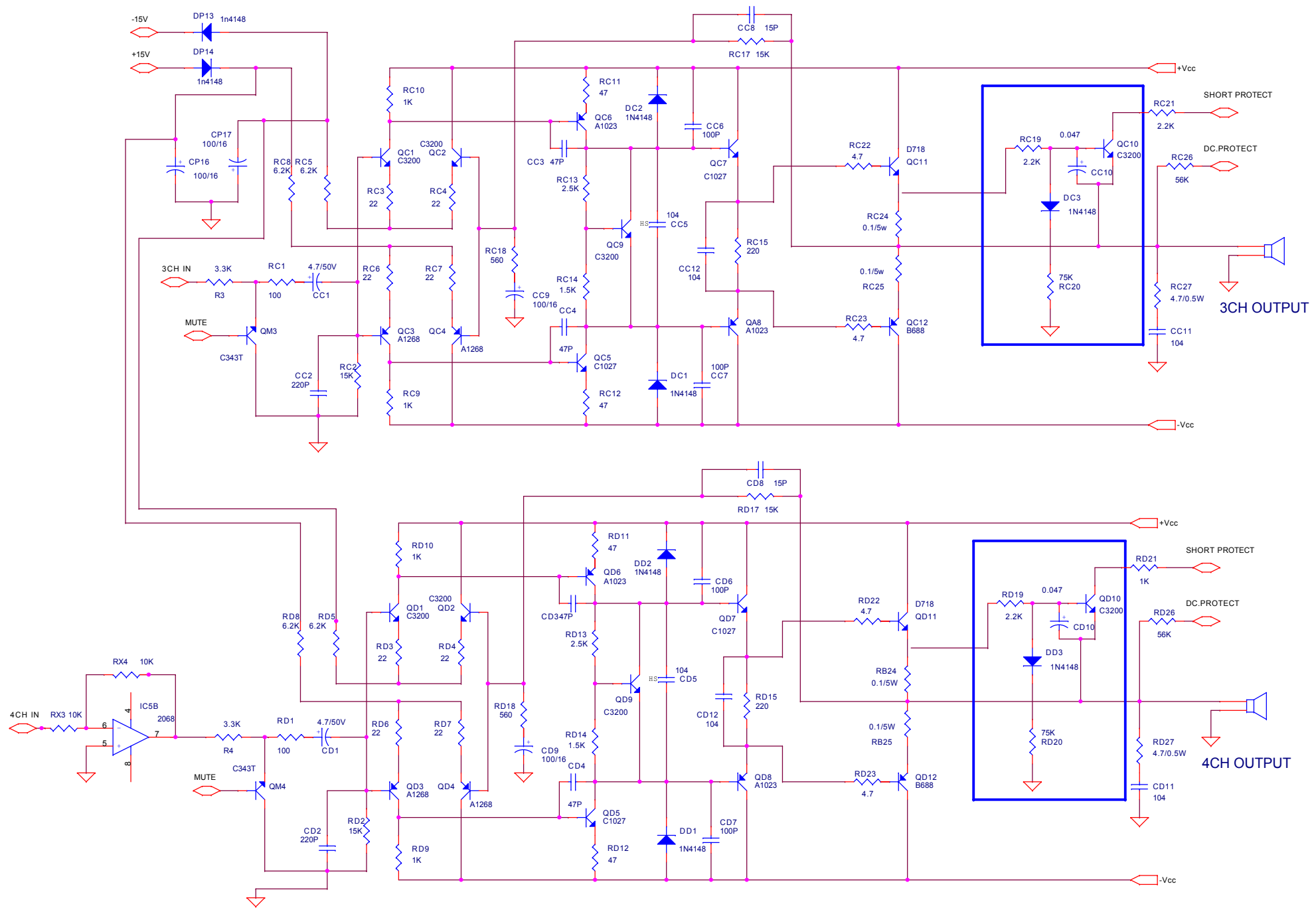

Title		
DARK BLUE4		
Size	Document Number	Rev
A3	AUDIO3/4	<Rev Code>
Date:	Friday, May 11, 2007	Sheet 1 of 1

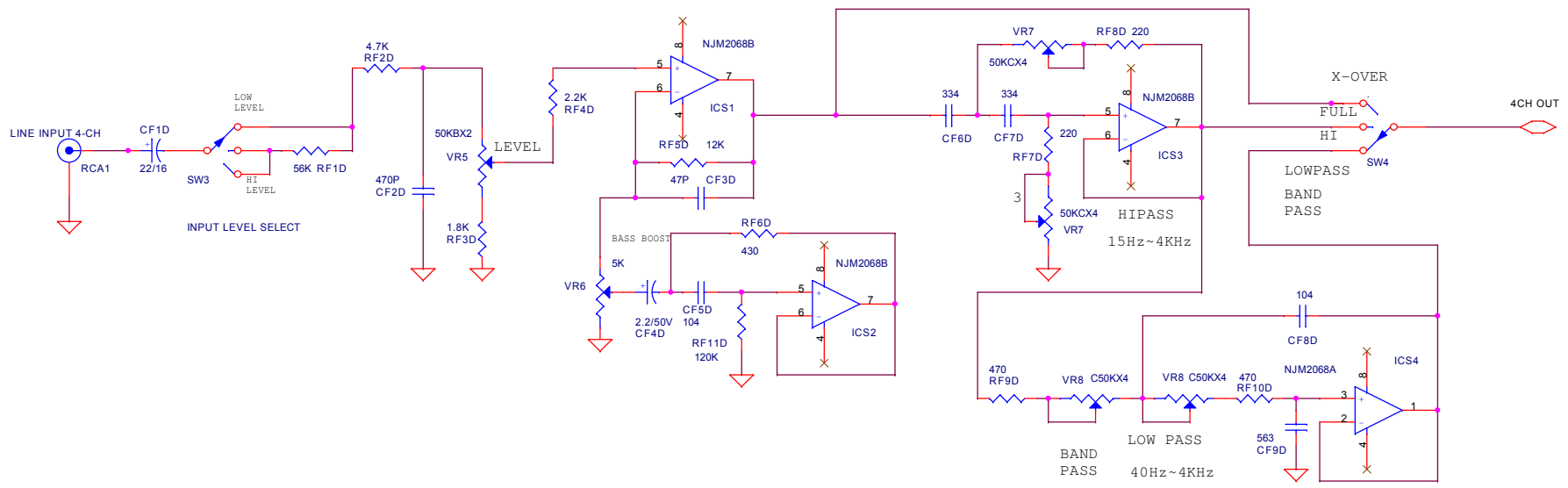
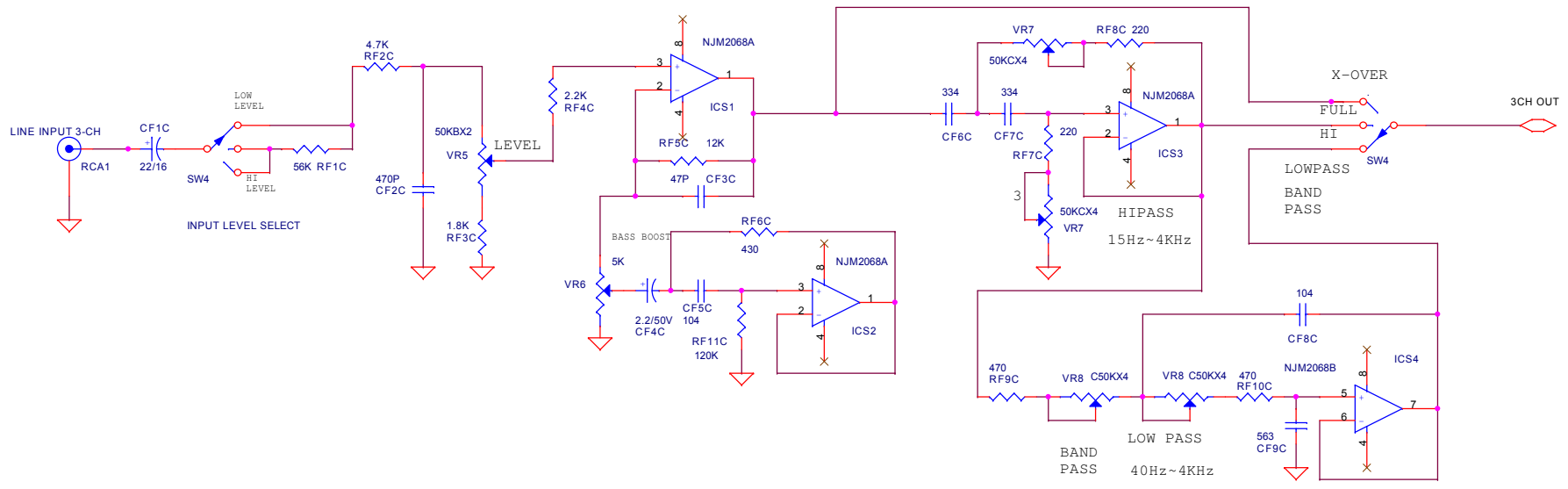

Title		
DARKB 4		
Size	Document Number	Rev
A3	INPUT & X-OVER 3/4	<RevCode>
Date:	Friday, May 11, 2007	Sheet 1 of 1

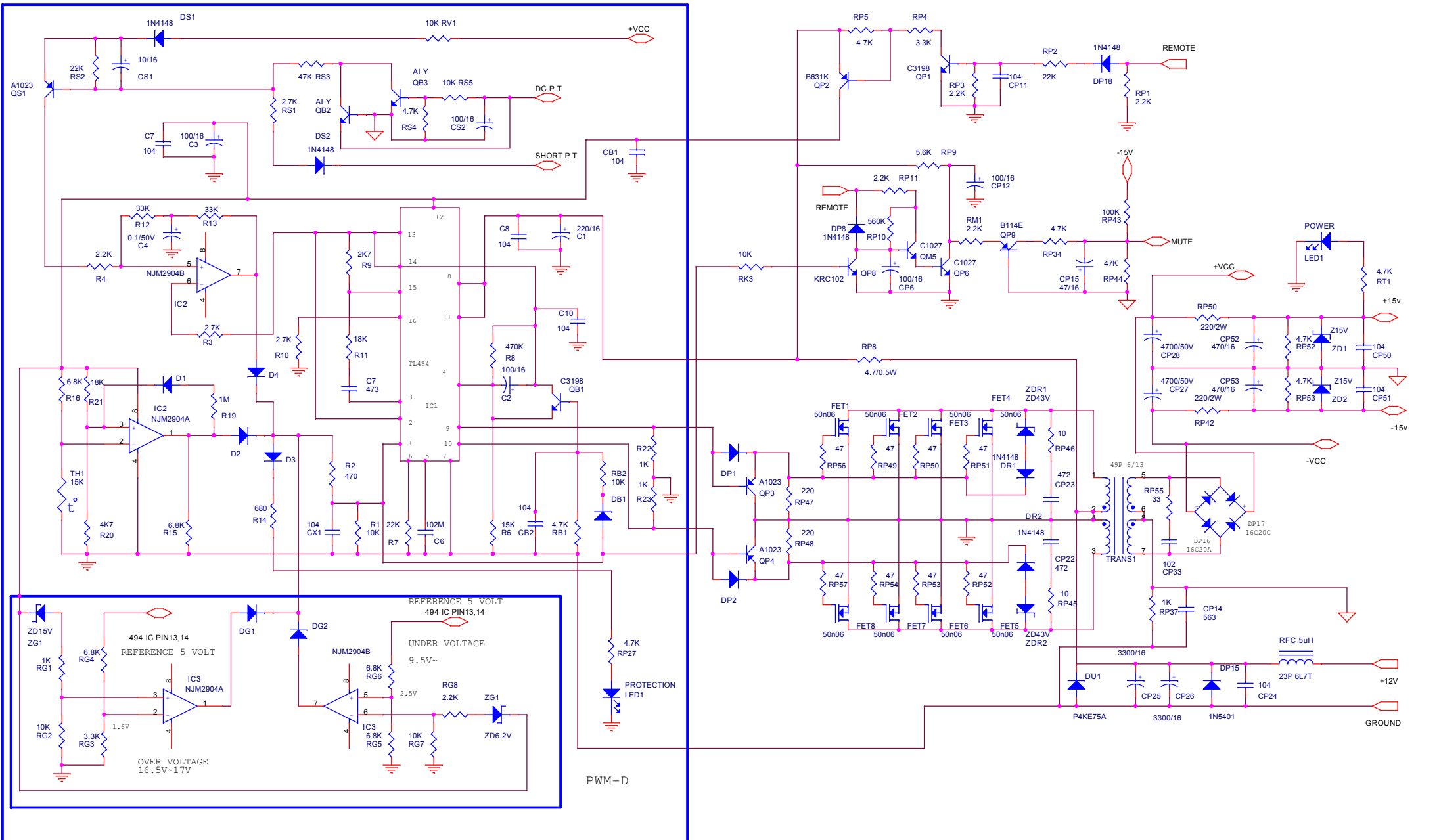

Title	DARK BLUE4		
Size	Document Number		Rev
Custom	POWER		<RevCode>
Date:	Friday, May 11, 2007	Sheet	1 of 1